

N<sup>o</sup> 12,039



A.D. 1896

*Date of Application, 2nd June, 1896*

*Complete Specification Left, 2nd Mar., 1897—Accepted, 2nd July, 1897*

PROVISIONAL SPECIFICATION.

**Improvements in Transmitting Electrical Impulses and Signals,  
and in Apparatus therefor.**

I, GUGLIELMO MARCONI, of 71 Hereford Road, Bayswater, in the County of Middlesex, do hereby declare the nature of this invention to be as follows:—

According to this invention electrical actions or manifestations are transmitted through the air, earth or water by means of electric oscillations of high frequency.

5 At the transmitting station I employ a Ruhmkorff coil having in its primary circuit a Morse key, or other appliance for starting or interrupting the current, and its pole appliances (such as insulated balls separated by small air spaces or high vacuum spaces, or compressed air or gas or insulating liquids kept in place by a suitable insulating material, or tubes separated by similar spaces, and carrying sliding  
10 discs) for producing the desired oscillations.

I find that a Ruhmkorff coil, or other similar apparatus, works much better if one of its vibrating contacts or brakes, on its primary circuit, is caused to revolve which causes the secondary discharge to be more powerful and more regular, and keeps the platinum contacts of the vibrator cleaner and preserves them in good working order  
15 for an incomparably longer time than if they were not revolved. I cause them to revolve by means of a small electric motor actuated by the current which works the coil, or by another current, or in some cases I employ a mechanical (non electrical) motor.

The coil may however be replaced by any other source of high tension electricity.  
20 At the receiving instrument there is a local battery circuit containing an ordinary receiving telegraphic or signalling instrument, or other apparatus which may be necessary to work from a distance and an appliance for closing the circuit, the latter being actuated by the oscillations from the transmitting instrument.

The appliance I employ consists of a tube containing conductive powder, or grains,  
25 or conductors in imperfect contact each end of the column of powder or the terminals of the imperfect contact or conductor being connected to a metallic plate, preferably of suitable length so as to cause the system to resonate electrically in unison with the electrical oscillations transmitted to it. In some cases I give these plates or  
30 conductors the shape of an ordinary Hertz resonator consisting of two semi-circular conductors, but with the difference that at the spark gap I place one of my sensitive tubes, whilst the other ends of the conductors are connected to small condensers.

I have found that the best rules for making the sensitive tubes are as follows:—

1st. The column of powder ought not to be long; the effects being better in sensitiveness, and regularity with tubes containing columns of powder or grains not  
35 exceeding two thirds of an inch in length.

2nd. The tube containing the powder ought to be sealed.

3rd. Each wire which passes through the tube, in order to establish electrical communication, ought to terminate with pieces of metal or small knobs of a comparatively large surface, or preferably with pieces of thicker wire, of a diameter  
40 equal to the internal diameter of the tube so as to oblige the powder or grains to be corked in between.

[Price 8d.]

BIRMINGHAM  
FREE LIBRARIES

*Marconi's Improvements in Transmitting Electrical Impulses, Signals, &c.*

4th. If it is necessary to employ a local battery of higher EMF than that with which an ordinarily prepared tube will work, the column of powder must be longer and divided into several sections by metallic divisions, the amount of powder or grains in each section being practically in the same condition as in a tube containing a single section. When no oscillations are sent from the transmitting instrument the powder or imperfect contact does not conduct the current, and the local battery circuit is broken, but when the powder or imperfect contact is influenced by the electrical oscillations it conducts and closes the circuit. 5

I find however that once started the powder or contact continues to conduct even when the oscillations at the transmitting station have ceased, but if it be shaken or tapped the circuit is broken. 10

I do this tapping automatically employing the current which the sensitive tube or contact had allowed to begin to flow under the influence of the electric oscillations from the transmitting instrument to work a trembler (similar to that of an electric bell) which hits the tube or imperfect contact, and so stops the current and consequently its own movement which had been generated by the said current which by this means automatically and almost instantaneously interrupts itself until another oscillation from the transmitting instrument repeats the process. Whilst for certain purposes I prefer working the trembler and the instruments on the same circuit which contains the sensitive tube or contact for other purposes I prefer working the trembler and the instruments on another circuit which is made to work in accordance with the first by means of a relay. It is by means of actions from the current which the sensitive tube or contact allows to pass when the oscillations influence it that I prefer starting the apparatus that has to interrupt automatically the same current. 20 25

In order to prevent the action of the self-induction of the local circuits on the sensitive tube or contact, and also to destroy the perturbing effect of the small spark which occurs at the breaking of the circuit inside the tube or imperfect contact and also at the vibrating contact of the trembler or at the movable contact of the relay I put in derivation across those parts where the circuit is periodically broken a condenser of suitable capacity, or a coil of suitable resistance and self-induction so that its self-induction may neutralise the self-induction of the said circuits, or preferably I employ in derivation on different parts of the circuit conductors or so called semi conductors of high resistance and small self-induction such as bars of charcoal or preferably tubes containing water or other suitable liquid, in electrical communication with those conductors of the local circuits which are liable in course of self induction to assume such differences of potential as to transmit jerky currents such as would influence the sensitive tube or contact so as to prevent its working with regularity. 30 35

In some cases however I find it suitable to employ an independent trembler moved by the current from another battery. This trembler is prevented from generating jerking or vibrating currents by means of the appliances which I have described. This trembler is kept going all the time during which one expects oscillations to be transmitted and as already described the powder or imperfect contact closes the circuit of a local battery, in which are included the instruments which one desires to work, for the time during which the electrical oscillations are transmitted, breaking the circuit in case of the mechanical vibrations as soon as the oscillations from the transmitting machine cease. When transmitting through the air, and it is desired that the signal or electrical action should only be sent in one direction, or when it is necessary to transmit electrical effects to the greatest possible distance without wires I place the oscillation producer at the focus or focal line of a reflector directed to the receiving station and I place the tube or imperfect contact at the receiving instrument in a similar reflector directed towards the transmitting instrument. 40 45 50

When transmitting through the earth or water I connect one end of the tube or contact to earth and the other ends to conductors or plates, preferably similar to each other, in the air and insulated from earth. 55

I find it also better to connect the tube or imperfect contact to the local circuit by

*Marconi's Improvements in Transmitting Electrical Impulses, Signals, &c.*

means of thin wires or across two small coils of thin and insulated wire preferably containing an iron nucleus.

Dated this 2nd day of June 1896.

GUGLIELMO MARCONI.

5

COMPLETE SPECIFICATION.

**Improvements in Transmitting Electrical Impulses and Signals,  
and in Apparatus therefor.**

I, GUGLIELMO MARCONI, of 67 Talbot Road, Westbourne Park, formerly residing at 71 Hereford Road, Bayswater, in the County of Middlesex, do hereby declare 10 the nature of this invention and in what manner the same is to be performed to be particularly described and ascertained in and by the following statement:—

My invention relates to the transmission of signals by means of electrical oscillations of high frequency, which are set up in space or in conductors.

In order that my specification may be understood, and before going into details, I 15 will describe the simplest form of my invention by reference to Figure 1.

In this diagram A is the transmitting instrument and B is the receiving instrument placed at say  $\frac{1}{4}$  mile apart.

In the transmitting instrument R is an ordinary induction coil (a Ruhmkorff coil or transformer).

20 Its primary circuit C is connected through a key D to a battery E and the extremities of its secondary circuit F are connected to two insulated spheres or conductors G H fixed at a small distance apart.

When the current from the battery E is allowed to pass through the primary of the induction coil, sparks will take place between the spheres G H and in consequence 25 the space all around the spheres suffers a perturbation in consequence of these electrical rays or surgings.

The arrangement A is commonly called a Hertz radiator and the effects which propagate through space Hertzian rays.

30 The receiving instrument B consists of a battery circuit J which includes a battery or cell K a receiving instrument L and a tube T containing metallic powder or filings, each end of the column of filings being also connected to plates or conductors M N of suitable size, so as to be preferably tuned with the length of wave of the radiation emitted from the transmitting instruments.

35 The tube containing the filings may be replaced by an imperfect electrical contact, such as two unpolished pieces of metal in light contact, or coherer, *etc.*

The powder in the tube T is under ordinary conditions a non conductor of electricity and the current of the cell K cannot pass through the instrument, but when the receiver is influenced by suitable electrical waves or radiation the powder in the tube T becomes a conductor (and remains so until the tube is shaken or tapped) 40 and the current passes through the instrument.

By these means electrical waves which are set up in the transmitting apparatus affect the receiving instrument in such a manner that currents are caused to circulate in the circuit J and may be utilized for deflecting a needle which thus responds to the impulse coming from the transmitter.

45 Figures 2, 3, 4, *etc.*, show various more complete arrangements of the above simple form of apparatus illustrated in Figure 1.

I will describe these figures generally before proceeding to describe the improvements in detail.

50 Figure 2 is a diagrammatic front elevation of the instruments of the receiving station, in which *k, k* are the plates corresponding to M N in Figure 1. *g* is the battery

*Marconi's Improvements in Transmitting Electrical Impulses, Signals, &c.*

corresponding to K, *h* is the reading instrument corresponding to L, *n* is a relay working the reading instrument *h* in the ordinary manner. *p* is a trembler or tapper, similar to that of an electric bell, which is moved by the current that works the instrument.

Figure 3 is a diagrammatic front elevation of the instruments at the transmitting station, in which *e e* are two metallic spheres corresponding to G, H in Figure 1. 5

*c* is an induction coil corresponding to R. *b* is a key corresponding to D and *a* is a battery corresponding to E.

Figure 4 is a vertical section of the radiator or oscillation producer mounted in the focal line of a cylindrical parabolic reflector *f* in which a side view of the 10 spheres *e e* of Figure 3 is given.

Figure 5 is a full sized view of the receiving plates *k k* and sensitive tube *j*.

Figure 5<sup>a</sup> is a modified form of sensitive tube.

Figure 6 is a modification of the oscillation producer in which the spheres *e e* and *d d* 15 are mounted in an ebonite tube *d<sup>3</sup>*.

Figure 7 is another modification of the oscillation producer in which the spheres are substituted by hemispheres.

Figure 8 is a modified form of receiver in which the plates *k k* are curved instead of being straight.

Figure 9 is another form of transmitter in which two large metallic plates *t<sup>2</sup> t<sup>2</sup>* are 20 employed.

Figure 10 shows a modification of the arrangements at the transmitting station and Figure 11 a modification of the arrangements of the receiving station which enables one to signal through obstacles such as hills or mountains.

Figure 12 shows a detector which is useful for determining the proper length of 25 the plates *k k* of the receivers.

Figure 13 shows an improved interruptor (make and break) which is applicable to the induction coil of the transmitter.

Figure 14 shows a water resistance, the use of which shall be explained.

My invention relates in great measure to the manner in which the above apparatus 30 are made and connected together. With some of these forms I am able to obtain Morse signals and to work ordinary telegraph instruments and other apparatus; and with modifications of the above apparatus it is possible to transmit signals not only through comparatively small obstacles such as brick walls, trees, *etc.*; but also through or across masses of metal, or hills or mountains, which may intervene between the 35 transmitting and receiving instruments.

I will first describe my improvements which are applicable to the receiving instruments.

My first improvement consists in automatically tapping or disturbing the powder in the sensitive tube, or in shaking the imperfect contact, so that immediately the 40 electrical stimulus from the transmitter has ceased, the tube or imperfect contact regains its ordinary non-conductive state. This part of my invention is illustrated in Figure 2 in which *j* represents the sensitive tube and *p* the trembler or tapper. The current which flows through the sensitive tube or contact and which is commenced under the influence of the electrical oscillations from the transmitting 45 instrument, is allowed to actuate (directly or indirectly by means of a relay) the trembler which is similar to that of an electric bell. This trembler must be so arranged as hereinafter explained that the effect of the sparking at its vibrating contacts, and the jerky currents caused by self-induction *etc.* are neutralized or removed. 50

The small hammer of the trembler hits the tube or imperfect contact and so stops the current and consequently its own movement which had been generated by the said current, and by this means the current automatically and almost instantaneously interrupts itself until another oscillation from the transmitting instrument again makes the sensitive tube or imperfect contact a conductor. 55

I find however that the current which can be started by the sensitive tube or contact is not sufficiently strong to work an ordinary trembler and receiving instrument.

*Marconi's Improvements in Transmitting Electrical Impulses, Signals, &c.*

To overcome this difficulty instead of obliging the current of the circuit which contains the sensitive tube or contact to work the trembler and instrument I use the said current for working a sensitive relay (*n* Figure 2) which closes and opens the circuit of a stronger battery *r* preferably of the Leclanche type. This current which  
 5 is much stronger than the current which runs through the sensitive tube or contact, works the trembler and other instruments. To prevent the sparks and jerks of current which would be caused by the self induction of the relay from interfering with the action of the receiver certain means must be taken similar to those referred to above in reference to the trembler or tapper which will be explained hereafter. In  
 10 the apparatus I have made I have found that the relay *n* should be one possessing small self induction, and wound to a resistance of about 1,000 ohms. It should preferably be able to work regularly with a current of a milliampère or less. The trembler or tapper *p* on the circuit of the relay *n* is similar in construction to that of a small electric bell but having a shorter arm. I have used a trembler wound to  
 15 1,000 ohms. resistance, having a core of good soft iron hollow and split lengthways like most electro-magnets used in telegraph instruments.

The trembler must be carefully adjusted. Preferably the blows should be directed slightly upwards so as to prevent the filings from getting caked. In place of tapping the tube the powder can be disturbed by slightly moving outwards and inwards one  
 20 or both of the stops of the sensitive tube (see Figure 5 *j*<sup>1</sup> *j*<sup>2</sup>) the trembler *p* (Figure 2) being replaced by a small electro-magnet or magnets or vibrator whose armature is connected to the stop.

I ordinarily work the receiving instrument *h* which may be of any description by a derivation as shown, from the circuit which works the trembler *p*. It can also  
 25 however be worked in series with the trembler.

It is desirable that the receiving instrument if on a derivation of the circuit which includes the trembler or tapper should preferably have a resistance equal to the resistance of the trembler *p*.

A further improvement consists in the mode of construction of the sensitive  
 30 tube.

I have noticed that a sensitive tube or imperfect contact such as is shown in Figure 1 *T* is not perfectly reliable.

My tube as shown in Figure 5 is if carefully constructed absolutely reliable, and by means of it the relay and trembler *etc.* can be worked with regularity like any  
 35 other ordinary telegraphic instrument.

In Figure 5 *j* is the sensitive tube containing two metallic plugs *j*<sup>2</sup> connected to the battery circuit, between which is placed powder of a conductive material *j*<sup>1</sup>. The two plugs should preferably be made of silver, or may be two short pieces of thick silver wire of the same diameter as the internal diameter of the tube *j* so as  
 40 to fit tightly in it. The plugs *j*<sup>2</sup> *j*<sup>2</sup> are joined to two pieces of platinum wire *j*<sup>3</sup>. The tube is closed and sealed on to the platinum wires *j*<sup>3</sup> at both ends. Many metals can be employed for producing the powder or filings *j*<sup>1</sup> but I prefer to use a mixture of two or more different metals. I find hard nickel to be the best metal and I prefer to add to the nickel filings about four *per cent.* of hard silver filings  
 45 which increase greatly the sensitiveness of the tube to electric oscillations. By increasing the proportion of silver powder or grains the sensitiveness of the tube also increases but it is better for ordinary work not to use a tube of too great sensitiveness as it might be influenced by atmospheric or other electricity.

The sensitiveness can also be increased by adding a very small amount of mercury  
 50 to the filings and mixing up until the mercury is absorbed. The mercury must not be in such a quantity as to clot or cake the filings, an almost imperceptible globule is sufficient for a tube. Instead of mixing the mercury with the powder one can obtain the same effects by slightly amalgamating the inner surfaces of the plugs which are to be in contact with the filings. Very little mercury must be used just  
 55 sufficient to brighten the surface of the metallic plugs without showing any free mercury or globules.

The size of the tube and the distance between the two metallic stops or plugs

*Marconi's Improvements in Transmitting Electrical Impulses, Signals, &c.*

may vary under certain limits, the greater the space allowed for the powder the larger or coarser ought to be the filings or grains.

I prefer to make my sensitive tubes of the following size—the tube  $j$  is  $1\frac{1}{2}$  inches long and  $\frac{1}{10}$  or  $\frac{1}{8}$  of an inch internal diameter. The lengths of the stops  $j^2$  is about  $\frac{1}{8}$  of an inch, and the distance between the stops or plugs  $j^2$  is about  $\frac{1}{10}$  of an inch. 5

I find, that the smaller or narrower the space is between the plugs in the tube the more sensitive it proves but the space cannot under ordinary circumstances be excessively shortened without injuring the fidelity of the transmission.

Care must be taken that the plugs  $j^2$  fit the tube exactly as otherwise the filings might escape from the space between the stops which would soon destroy the action of the sensitive tube. 10

The metallic powders ought not to be fine but rather coarse, as can be produced by a large and rough file.

The powder should preferably be of uniform grain or thickness. 15  
All the very fine powder or the excessively coarse powder ought to be removed from it by blowing or sifting.

It is also desirable that the powder or grains should be dry and free from grease or dirt and the files used in producing the same ought to be frequently washed and dried and used when warm. 20

The powder ought not to be compressed between the plugs but rather loose, and in such a condition that when the tube is tapped the powder may be seen to move freely.

The tube  $j$  may be sealed but a vacuum inside it is not essential except perhaps the slight vacuum which results from having heated it while sealing it. Care should also be taken not to heat the tube too much in the centre when sealing it as it would oxidize the surfaces of the silver stops and also the powder which would diminish its sensitiveness. I have used in sealing the tubes a hydrogen and air flame. 25

A vacuum is however desirable and I have used one of about  $\frac{1}{1000}$  of an atmosphere obtained by a mercury pump. 30

In this case a small glass tube must be joined to a side of the tube  $j$  (Figure 5) which is put in communication with the pump and afterwards sealed in the ordinary manner.

If the sensitive tube has been well made it should be sensitive to the inductive effect of an ordinary electric bell when the same is working from one to two yards from the tube. 35

A sensitive tube well prepared should also instantly interrupt the current passing through it at the slightest tap or shake provided it is inserted in a circuit in which there is little self-induction, and small electro motive force such as a single cell. 40

In order to keep the sensitive tube  $j$  in good working order it is desirable but not absolutely necessary not to allow more than one milliamperè to flow through it when active.

If a stronger current is necessary several tubes may be put in parallel provided they all get shaken by the tapper or trembler, but this arrangement is not always quite as satisfactory as the single tube. 45

It is preferable when using sensitive tubes of the type I have described not to insert in the circuit with it more than one cell of the Leclanchè type as a higher electro motive force than 1.5 volts is apt to pass a current through the tube even when no oscillations are transmitted. 50

I can however construct sensitive tubes capable of working with a higher electro-motive force.

Figure 5<sup>a</sup> shows one of these tubes. In this tube instead of one space or gap filled with filings there are several spaces  $j^1$  separated by plugs of tight fitting silver wire. A tube thus constructed observing also the rules of construction of my tubes in general will work satisfactorily if the electro-motive force of the battery in circuit with the tube is equal to about 1.2 volts multiplied by the number of gaps. 55

*Marconi's Improvements in Transmitting Electrical Impulses, Signals, &c.*

With this tube also it is well not to allow a current of more than one milliampère to pass through it.

Figure 5 also shows the plates *k k* which are joined to each end of the sensitive tube, and which correspond to the plates *M N* in Figure 1.

5 The plates *k* (Figure 5) are of copper or other metal about half an inch or more broad, and may be about  $\frac{1}{60}$  of an inch thick and preferably of such a length as to be electrically tuned with the length of the wave of the electrical oscillations transmitted.

The means I adopt for fixing the proper length of the plates *k k* is as follows:—  
 10 I stick a rectangular strip of tin foil (see Figure 12) *m* about 20 inches long (the length depends on the supposed length of wave that one is measuring) by means of a weak solution of gum on to a glass plate *m*<sup>1</sup> (Figure 12); then by means of a very sharp penknife or point and ruler I cut across the middle of the tin foil leaving a mark of division *m*<sup>2</sup>. If this glass plate is held a few feet away from the origin of the  
 15 electrical disturbances, and in such a position that the strips of tin foil are about parallel to the line joining the centres of the two spheres in the transmitting apparatus, sparks will jump from one strip to the other at *m*<sup>2</sup>. When the length of the strips of tin foil *m* has been so adjusted as to approximate to the length of wave emitted from the oscillator the sparking will occur at a greater distance from the oscillation  
 20 producer when the strips are of suitable length. By shortening or lengthening the strips therefore it is easy to find the length most appropriate to the length of wave emitted by the oscillation producer. The length so found is the proper length for the plates *k* or rather these should be about half an inch shorter on account of the length of the sensitive tube *j* (Figure 5) connected between them.

25 The plates *k* tube *j* etc. are fastened to a thin glass tube *o* preferably not longer than 12 inches firmly fixed at one end to a firm piece of wood *o*<sup>2</sup>, or the sensitive tube *j* may be fixed firmly at both ends *i.e.* preferably grasped near the ends of the tube containing the powder and not at the ends of the tube *o o* which serves as support.

30 By means of a tube with multiple gaps as shown in Figure 5<sup>a</sup> it is also possible to work the trembler and also the signalling or other apparatus direct on the circuit which contains the sensitive tube, but I prefer when possible to work with the single gap tube and the relay as shown. With a sensitive and specially constructed trembler it is also possible to work the trembler with the single gap tube in series with it  
 35 without a relay.

In order to increase the distance at which the receiver can be actuated by the radiation from the transmitter, I place the receiver (*i.e.* the sensitive tube and plates) in the focal line of a cylindrical parabolic reflector *l* (Figure 2) preferably of copper and directed towards the transmitting station.

40 In determining the proper length of the plates of the receiver by means of the detector shown in Figure 12 it is desirable to try the detector in the focus or focal line of the reflector, because the length of the strips or plates which give the best result in a reflector differs slightly from the length which gives the best results without reflectors.

45 The reflector *l* (Figure 2) should be preferably in length and opening not less than double the length of wave emitted from the transmitting instrument.

It is slightly advantageous for the focal distance of the reflector to be equal to one fourth or three fourths of the wave length of the oscillation transmitted.

The plates *k* (Figure 2) may be replaced by tubes or other forms of conductors.

50 A further improvement has for its object to prevent the electrical disturbances which are set up by the trembler and other apparatus in proximity or in circuit with the tube from themselves restoring the conductivity of the sensitive tube, immediately after the trembler has destroyed it as has been described.

This I effect by introducing into the circuits at the places marked *p*<sup>1</sup> *p*<sup>2</sup> *q* *h*<sup>1</sup> in  
 55 Figure 2 high resistances having as little self induction as possible. The action of the high resistance is while preventing any appreciable quantity of the current from passing through them when the apparatus is working nevertheless afford an easy

*Marconi's Improvements in Transmitting Electrical Impulses, Signals, &c.*

path for the currents of high tension which would be formed at the moment when the circuit is broken, and thus prevent sparking at contacts or sudden jerks of currents which would restore or maintain the conductivity of the sensitive tube.

These coils may conveniently be made by winding the wire (preferably of platinoid) on the bight, as it is sometimes termed or double wound to prevent them producing self induction. 5

In Figure 2  $p^2$  is one of these resistance coils which is inserted in a circuit connecting the vibrating contacts of the trembler  $p$ . I have used in the apparatus a coil which had a resistance about four times the resistance of the trembler  $p$ .

$p^1$  represents a similar resistance (also of about four times the resistance of the trembler) inserted in parallel across the terminals of the trembler. 10

A similar resistance  $q$  Figure 2 is placed in parallel on the terminals of the relay  $n$  (*i.e.* the terminals which are connected to the circuit containing the sensitive tube).

The coil  $q$  should preferably have a resistance of about three or four times the resistance of the relay. 15

A similar resistance  $h^1$  of about four times the resistance of the instrument is inserted in parallel across the terminals of the instrument.

In parallel across the terminals of the relay (*i.e.* corresponding to the circuit worked by the relay) it is well to have a liquid resistance  $s$  constituted of a series of tubes one of which is shown full size in Figure 14 partially filled with water acidulated with sulphuric acid. The number of these tubes in series across the said terminals ought to be about ten for a circuit of 15 volts so as to prevent in consequence of their counter electro-motive force, the current of the local battery from passing through them, but allowing the high tension jerk of current generated at the opening of the circuit in the relay to pass smoothly across them without producing perturbing sparks at the moveable contact of the relay. 20 25

A double wound platinoid resistance may be used instead of the water resistance provided its resistance be about 20,000 ohms.

A resistance similar to  $h$  should be inserted in parallel on the terminals of any apparatus or resistance which may be apt to give self-induction and which is near or connected to the receiver. 30

Condensers of suitable capacity may be substituted to the above mentioned coils, but I prefer using coils or water resistances.

Another improvement has for its object to prevent the high frequency oscillations set up across the plates of the receiver by the transmitting instrument which should pass through the sensitive tube, from running round the local battery wires, and thereby weakening their effect on the sensitive tube or contact. 35

This I effect by connecting the battery wires to the sensitive tube or contact or to the plates attached to the tube through small coils (see  $k^1$  in the figures) possessing self-induction; which may be called choking coils, formed by winding in the ordinary manner a short length (about a yard) of thin and well insulated wire round a core (preferably containing iron) two or three inches long. 40

Another improvement consists in a modified form of the plates connected to the sensitive tube in order to make it possible to mount the receiver in an ordinary circular parabolic reflector. This part of my invention is illustrated in Figure 8 in which  $l$  is an ordinary concave reflector. In this case the plates  $k k$  are curved and connected at one end to the sensitive tube  $j$  and at the other to a small condenser formed by two metallic plates  $k^2$  of about one inch square, or more facing each other with a very thin piece of insulating material  $k^3$  between them.  $p$  is the trembler. The condenser may be omitted without much altering the effects obtainable. 45 50

The connection to the local circuit are made through two small choking coils  $k^1 k^1$  as already described.

The adjustment of the whole is similar to that already described for the other receivers. 55

The receiver should be put in such a position as to intercept the reflected ring of radiations which exists behind or before the focus of the reflector, and ought to be



*Marconi's Improvements in Transmitting Electrical Impulses, Signals, &c.*

preferably tuned with the length of wave of the oscillation transmitted, in similar manner to that before described except that a ring of tin foil with a single cut through it is employed.

I will now describe my improvements which are applicable to the transmitting  
5 instruments.

My first improvement consists in employing four spheres for producing the electrical oscillations.

This part of my invention is illustrated in Figure 3 *d d e e* and in Figure 6 *d d e e*. The spheres *d d* Figure 3 are connected to the terminals *c'* of the secondary circuit  
10 of the induction coil *c*. The spheres *d d* are carried by insulating supports *d<sup>1</sup> d<sup>1</sup>*.

Preferably the supports *d<sup>1</sup>* consist of plates of ebonite having holes to receive the balls which are fixed by heating them sufficiently to fuse the ebonite and then holding them in place until they cool. *e e* are two similar balls on supports *e<sup>1</sup> e<sup>1</sup>* whose distance apart can be adjusted by ebonite bolts and nuts *e<sup>2</sup> e<sup>2</sup>* acting against other nuts *e<sup>3</sup>*. *e<sup>4</sup>* is  
15 a flexible membrane preferably of parchment paper glued to the supports *e<sup>1</sup>* and forming a vessel which is filled with di-electric liquid preferably vaseline oil slightly thickened with vaseline.

The oil or insulating liquid between the spheres *e e* increases the power of the radiation and also enables one to obtain constant effects, which are not easily  
20 obtained if the oil is omitted.

The balls *d* and *e* are preferably of solid brass or copper and the distance they should be apart depends on the quantity and electro-motive force of the electricity employed the effect increasing with the distance (especially by increasing the distance between the spheres *d* and the spheres *e*) so long as the discharge passes freely. With an  
25 induction coil giving an ordinary 8 inch spark the distance between *e* and *e* should be from  $\frac{1}{25}$  to  $\frac{1}{30}$  of an inch and the distance between *d* and *e* about one inch.

When it is desired that the signal should only be sent in one direction I place the oscillation producer in the focus or focal line of a reflector directed to the receiving station.

30 *f* (Figure 3) and *f* (Figure 4) shows the cylindrical parabolic reflector made by bending a metallic sheet preferably of brass or copper to form and fixing it to metallic or wooden ribs *f<sup>1</sup>* (Figure 3).

Other conditions being equal the larger the balls the greater is the distance at which it is possible to communicate. I have generally used balls of solid brass of 4 inches  
35 diameter giving oscillations of 10 inches length of wave.

Instead of spheres, cylinders or ellipsoids *etc.* may be employed.

Preferably the reflector applied to the transmitter ought to be in length and opening the double at least of the length of wave emitted from the oscillator.

If these conditions are satisfied and with a suitable receiver, a transmitter furnished  
40 with spheres of four inches diameter connected to an induction coil giving a 10 inch spark will transmit signals to two miles or more.

If a very powerful source of electricity giving a very long spark be employed it is preferable to divide the spark gap between the central balls of the oscillator into several smaller gaps in series. This may be done by introducing between the  
45 big balls smaller ones (of about half an inch diameter) held in position by ebonite frames.

Figure 6 shows a more compact form of oscillation producer. In this each pair of balls *d* and *e* are fixed by heat or otherwise in the end of tubes *d<sup>2</sup>* of insulating material such as ebonite or vulcanite. The tubes *d<sup>2</sup>* fit tightly in another similar  
50 tube *d<sup>3</sup>* having covers *d<sup>4</sup>* through which pass the rods *d<sup>5</sup>* connecting the balls *d* to the conductors. One (or both) of the rods *d<sup>5</sup>* is connected to the ball *d* by a ball and socket joint and has a screw thread upon it working in a nut in the cover *d<sup>4</sup>*. By turning the rod therefore the distance of the balls *e* apart can be adjusted. *d<sup>6</sup>* are holes in the tube *d<sup>3</sup>* through which the vaseline oil can be introduced into the space  
55 between the balls *e*.

A further improvement consists in causing one of the contacts of the vibrating brake applied to the induction coil to revolve rapidly.

*Marconi's Improvements in Transmitting Electrical Impulses, Signals, &c.*

This improvement has for its object to maintain the platinum contacts of the interrupter in good working order, and to prevent them sticking *etc.*

This part of my invention is illustrated in Figure 3 ( $c^2 c^3 c^4$ ).

I obtain this result by having a revolvable central core  $c^2$  (Figure 3 and Figure 13) in the ordinary screw  $c^3$  which is in communication with the platinum contacts. I cause the said central core with one of the platinum contacts attached to it to revolve by coupling it to a small electric motor  $c^4$ .

This motor can be worked by the same circuit that works the coil or if necessary by a separate circuit—the connections are not shown in the drawing.

By this means the regularity and power of the discharge of an ordinary induction coil with a trembler brake is greatly improved.

The induction coil  $c$  (Figure 3) may however be replaced by any other source of high tension electricity.

When working with large amounts of energy it is however better to keep the coil of transformer constantly working for the time during which one is transmitting, and instead of interrupting the current of the primary, interrupting the discharge of the secondary.

In this case the contacts of the key should be immersed in oil as otherwise owing to the length of the spark the current will continue to pass after the contacts have been separated.

A further improvement has for its object to facilitate the focussing of the electric rays.

This part of my invention is illustrated in Figure 7 in which a view is given of the modified oscillation producer mounted in the focus of an ordinary parabolic reflector  $f$ .

The oscillator in this case is different from the one I have previously described because instead of being constituted of two spheres it is made of two hemispheres  $e e$  separated by a small space filled with oil or other dielectric. The spark between the hemispheres takes place in the dielectric from small projections at the centres of the hemispheres. The working and adjusting of this oscillator is similar to that of the one previously described.

This arrangement may also be solidly mounted in an ebonite tube as shown in Figure 6.

A receiver which may be used with this transmitter is shown in Figure 8 and has also been described.

It is not essential to have a reflector at the transmitters and receivers, but in their absence the distance at which one can communicate is much smaller.

Figure 9 shows another modified form of transmitter with which one can transmit signals to considerable distances without using reflectors.

In Figure 9  $t t$  are two poles connected by a rope  $t^1$  to which are suspended by means of insulating suspenders two metallic plates  $t^2 t^2$  connected to the spheres  $e$  (in oil or other dielectric as before) and to the other balls  $t^3$  in proximity to the spheres  $c^1$  which are in communication with the coil or transformer  $c$ . The ball  $t^3$  are not absolutely necessary as the plates  $t^2$  may be made to communicate with the coil or transformer by means of thin insulated wires. The receiver I adopt with this transmitter is similar to it, except that the spheres  $e$  are replaced by the sensitive tube or imperfect contact  $j$  (Figure 5); whilst the spheres  $t^3$  may be replaced by the choking coils  $k^1$  in communication with the local circuit. If a circular tuned receiver of large size be employed the plates  $t^2$  may be omitted from the receiver. I have observed that other conditions being equal larger the plates at the transmitter and receiver and the higher they are from earth and to a certain extent the further apart they are the greater is the distance at which correspondence is possible.

The permanent installations it is convenient to replace the plates by metallic cylinders closed at one end, and put over the pole like a hat, and resting on insulators. By this arrangement no wet can come so the insulators and the effects obtainable are better in wet weather.

*Marconi's Improvements in Transmitting Electrical Impulses, Signals, &c.*

A cone or hemisphere may be used in place of a cylinder. The pole employed ought preferably to be dry and tarred.

Where obstacles such as many houses or a hill or mountains intervene between the transmitter and the receiver, I have devised and adopt the arrangement shown in  
5 Figures 10 and 11.

In the transmitting instrument Figure 10 I connect one of the spheres *d* to earth E preferably by a thick wire and the other to a plate or conductor *u* which may be suspended on a pole *v* and insulated from earth. Or the spheres *d* may be omitted and one of the spheres *e* be connected to earth and the other to the plate or  
10 conductor *u*.

At the receiving station Figure 11, I connect one terminal of the sensitive tube or imperfect contact *j* to earth E preferably also by a thick wire, and the other to a plate or conductor *w* preferably similar to *u*. The plate *w* may be suspended on a pole *x* and should be insulated from earth. The larger the plates of the receiver and  
15 transmitter, and the higher from the earth the plates are suspended, the greater is the distance at which it is possible to communicate at parity of other conditions.

The figure does not show the trembler or tapping arrangement. *k*<sup>1</sup> *k*<sup>1</sup> are the choking coils which are connected to the battery circuit as has been explained with reference to the previous figures.

In permanent installations it is convenient to replace the plates by metallic cylinders closed at one end, and put over the pole like a hat, and resting on insulators.

Also a cone or hemisphere may be used in place of a cylinder. The pole employed ought preferably to be dry and tarred.

At the receiver it is possible to pick up the oscillations from the earth or water without having the plate *w*. This may be done by connecting the terminals of the sensitive tube *j* to two earths preferably at a certain distance from each other and in a line with the direction from which the oscillations are coming. These connections must not be entirely conductive but must contain a condenser of suitable capacity,  
30 say of one square yard surface (parafined paper as dielectric).

Balloons can also be used instead of plates on poles provided they carry up a plate or are themselves made conductive by being covered with tin foil. As the height to which they may be sent is great the distance at which communication is possible becomes greatly multiplied. Kites may also be successfully employed if  
35 made conductive by means of tin foil.

When working the described apparatus it is necessary either that the local transmitter and receiver at each station should be at a considerable distance from each other or that they should be screened from each other by metal plates. It is sufficient to have all the telegraphic apparatus in a metal box, (except the reading instrument)  
40 and any exposed part of the circuit of the receiver enclosed in metallic tubes which are in electrical communication with the box (of course the part of the apparatus which has to receive the radiation from the distant station must not be enclosed, but possibly screened from the local transmitting instrument by means of metallic sheets).

When the apparatus is connected to the earth or water the receiver must be switched out of circuit when the local transmitter is at work and this may also be done when the apparatus is not earthed.

Having now particularly described and ascertained the nature of my said invention and in what manner the same is to be performed, I declare that what  
50 I claim is:—

1. The method of transmitting signals by means of electrical impulses to a receiver having a sensitive tube or other sensitive form of imperfect contact capable of being restored with certainty and regularity to its normal condition substantially as described.

55 2. A receiving instrument consisting of a sensitive imperfect contact, or contacts, a circuit through the contact, or contacts, and means for restoring the contact, or

*Marconi's Improvements in Transmitting Electrical Impulses, Signals, &c.*

contacts, with certainty and regularity, to its, or their normal condition after the receipt of an impulse substantially as described.

3. A receiving instrument consisting of a sensitive imperfect contact, or contacts, a circuit through the contact, or contacts, and means actuated by the circuit for restoring with certainty and regularity, the contact, or contacts, to its or their normal condition after the receipt of an impulse.

4. In a receiving instrument such as is mentioned in Claims 2 and 3, the use of resistances possessing low self-induction, or other appliances for preventing the formation of sparks at contacts or other perturbing effects.

5. The combination with the receivers such as are mentioned in Claims 2 and 3 of resistances or other appliances for preventing the self-induction of the receiver from affecting the sensitive contact, or contacts, substantially as described.

6. The combination with receivers such as herein above referred to of choking coils substantially as described.

7. In receiving instruments consisting of an imperfect contact, or contacts, sensitive to electrical impulses the use of automatically working devices for the purpose of restoring the contact, or contacts, with certainty and regularity, to their normal condition after the receipt of an impulse substantially as herein described.

8. Constructing a sensitive non-conductor capable of being made a conductor by electrical impulses of two metal plugs or their equivalents and confining between them some substance such as described.

9. A sensitive tube containing a mixture of two or more powders grains or filings substantially as described.

10. The use of mercury in sensitive imperfect electrical contacts substantially as described.

11. A receiving instrument having a local circuit including a sensitive imperfect electrical contact, or contacts, and a relay operating an instrument for producing signals actions or manifestations substantially as described.

12. Sensitive contacts in which a column of powder or filings (or their equivalent) is divided into sections by means of metallic stops or plugs substantially as described.

13. Receivers substantially as described and shown in Figures 5 and 8.

14. Transmitters substantially as described and shown at Figures 6 and 7.

15. A receiver consisting of a sensitive tube or other imperfect contact inserted in a circuit, one end of the sensitive tube or other imperfect contact being put to earth whilst the other end is connected to an insulated conductor.

16. The combination of a transmitter having one end of its sparking appliance or poles connected to earth, and the other to an insulated conductor, with a receiver as is mentioned in Claim 15.

17. A receiver consisting of a sensitive tube or other imperfect contact inserted in a circuit, and earth connections to each end of the sensitive contact or tube through condensers or their equivalent.

18. The modifications in the transmitters and receivers in which the suspended plates are replaced by cylinders or the like placed hat-wise on poles, or by balloons or kites substantially as described.

19. An induction coil having a revolving make and break substantially as and for the purposes described.

Dated this 2nd day of March 1897.

GUGLIELMO MARCONI.

50

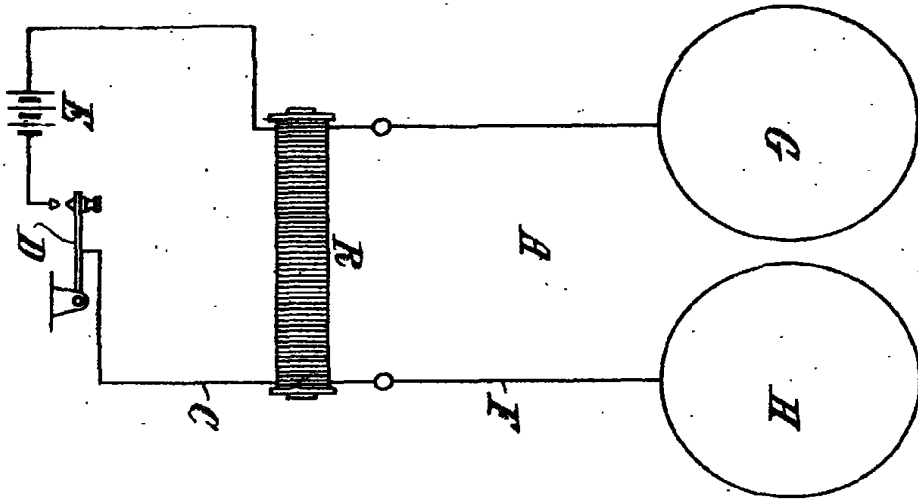
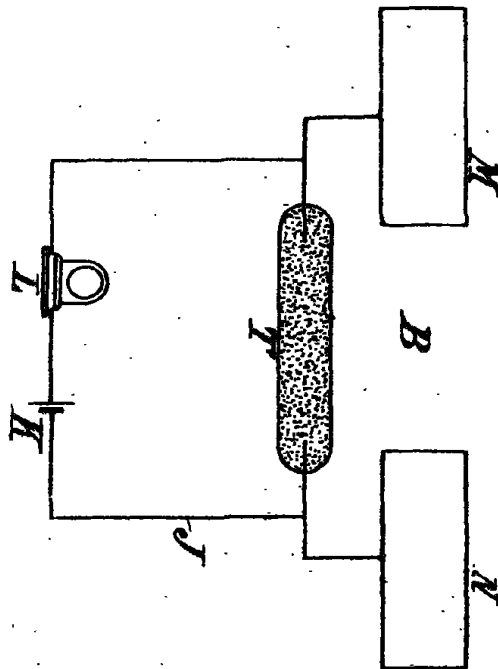

Fig. 1.



[This Drawing is a reproduction of the Original on a reduced scale]

Malby & Sons, Photo-Litho.

BIRMINGHAM  
FREE LIBRARIES



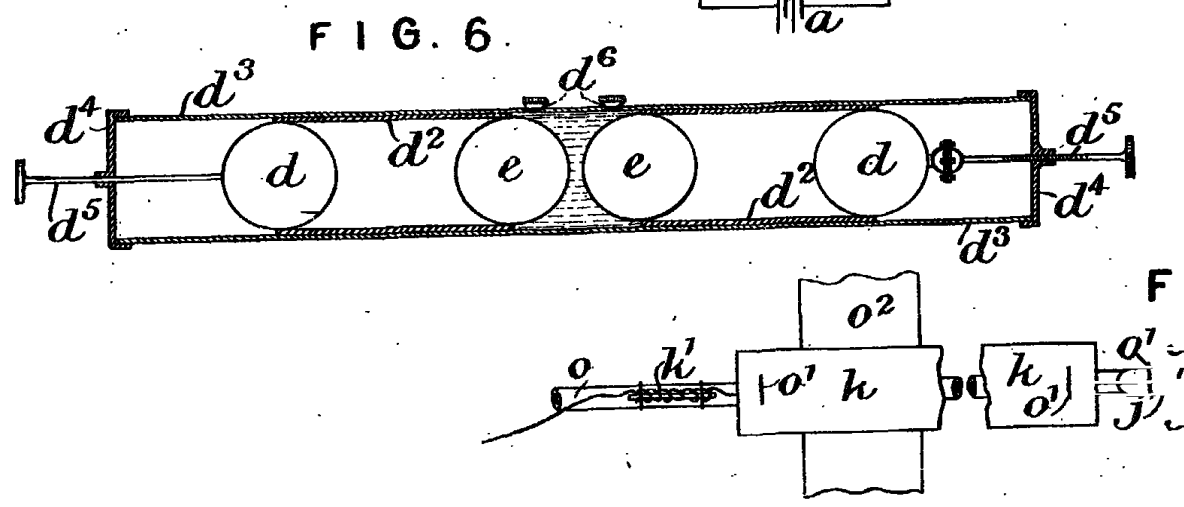
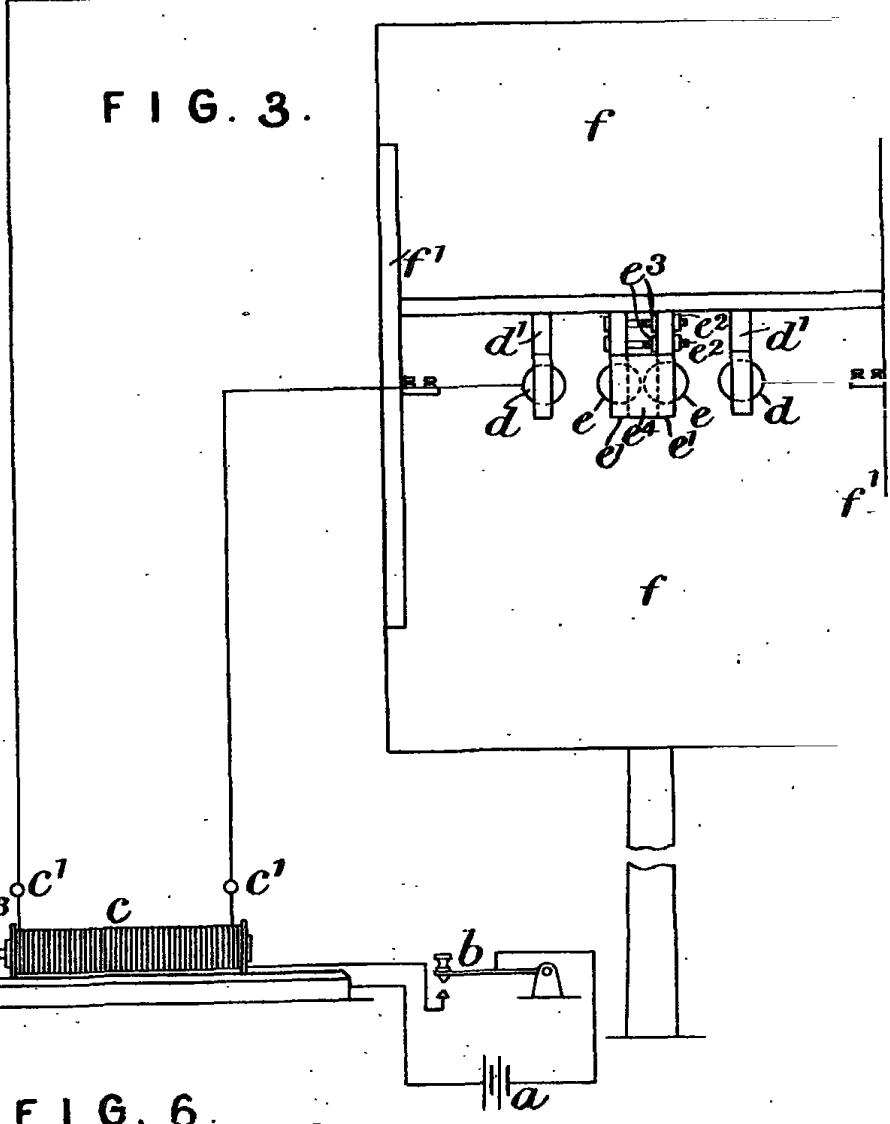
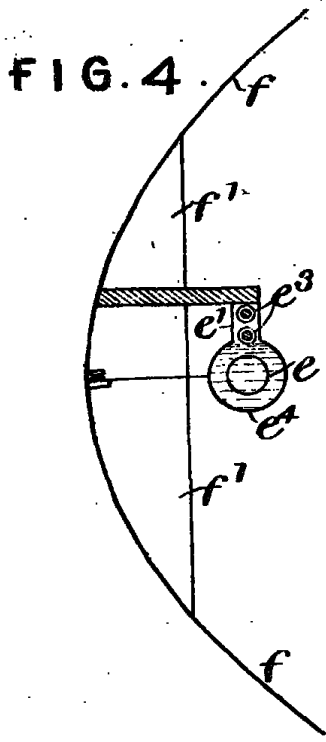

FIG. 2.

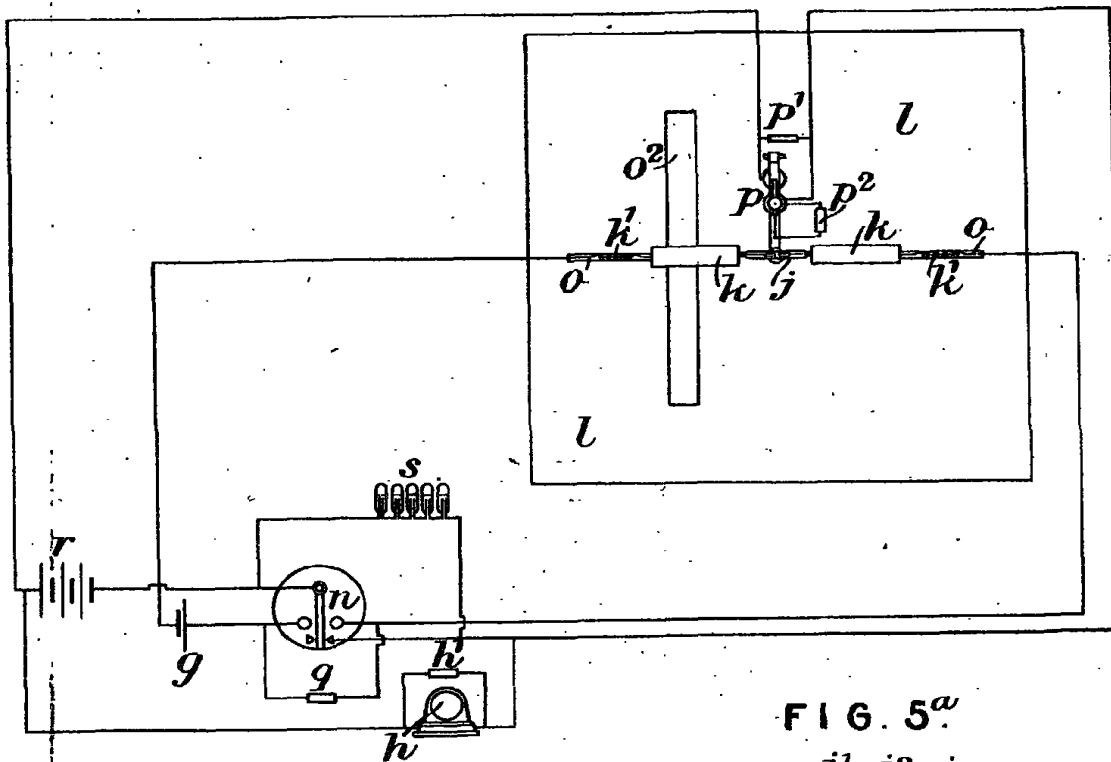

FIG. 13.

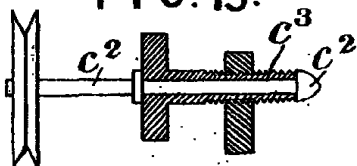

FIG. 5<sup>a</sup>.

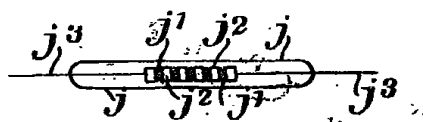

FIG. 12.

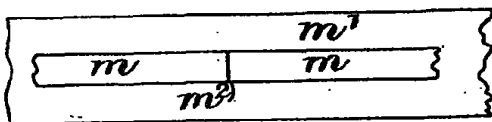

FIG. 14.

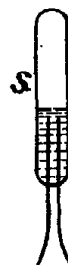

FIG. 5.



[This Drawing is a reproduction of the Original on a reduced scale.]



FIG. 7.

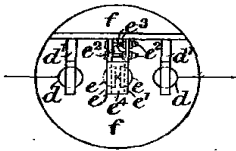

FIG. 8.

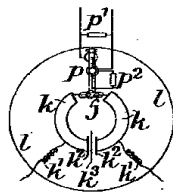

FIG. 10.

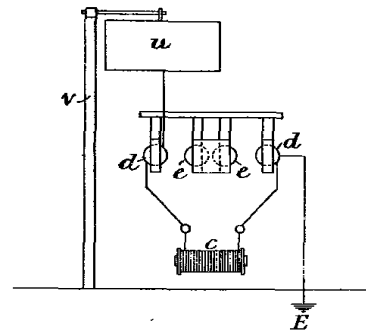

FIG. 9.

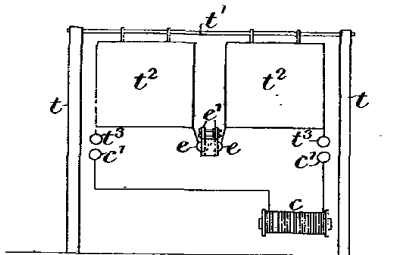
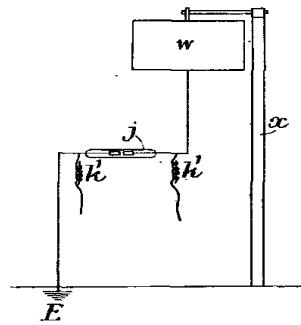

FIG. 11.



[This drawing is a reproduction of the original and is not reduced in size.]

Moly & Sons Photo-Litho

BIRMINGHAM  
FREE LIBRARIES

FIG 7

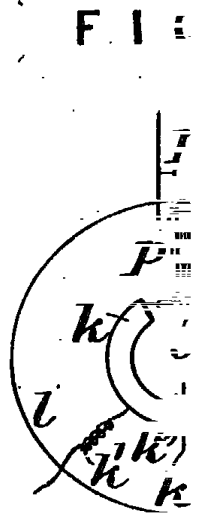
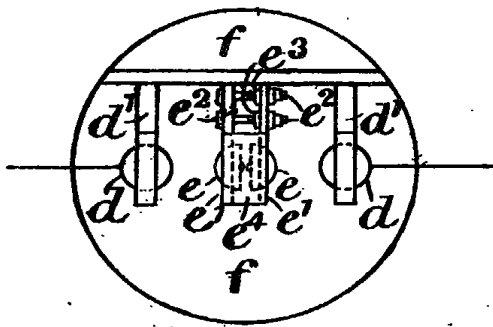

FIG. 9.

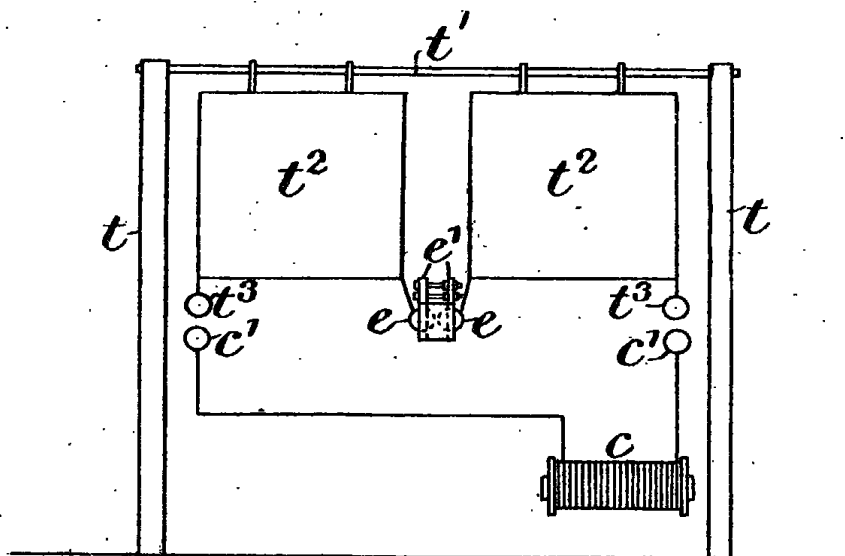

FIG. 10.

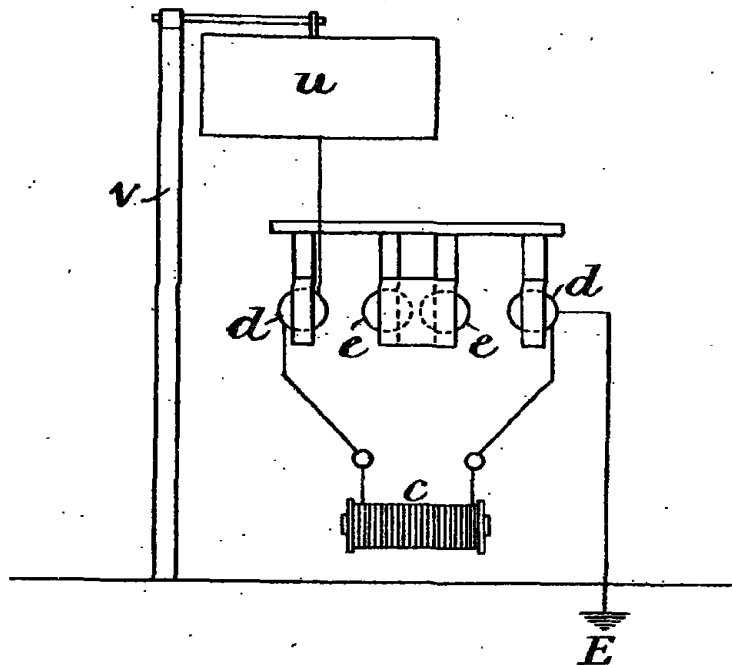
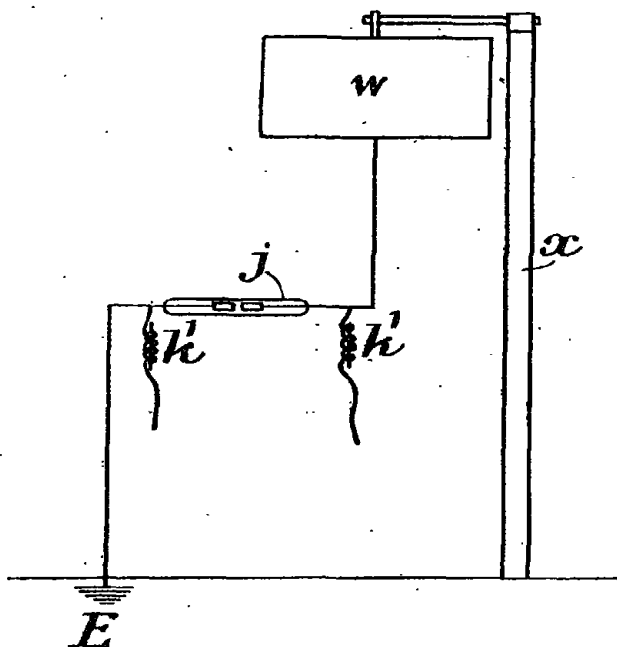

FIG. 11.



[This Drawing is a reproduction of the Original on a reduced scale.]