

(19)



(11)

EP 3 054 658 B1

(12)

EUROPEAN PATENT SPECIFICATION

(45) Date of publication and mention of the grant of the patent:
27.09.2017 Bulletin 2017/39

(51) Int Cl.:
H04M 1/247^(2006.01) H04M 1/725^(2006.01)
H04M 1/2745^(2006.01)

(21) Application number: **16157698.8**

(22) Date of filing: **20.11.2006**

(54) METHOD AND DEVICE FOR COMMUNICATION CHANNEL SELECTION

VERFAHREN UND VORRICHTUNG ZUR KOMMUNIKATIONSKANALWAHL

PROCEDE ET DISPOSITIF DE COMMUNICATION DE SELECTION DE CANAL

(84) Designated Contracting States:
AT BE BG CH CY CZ DE DK EE ES FI FR GB GR HU IE IS IT LI LT LU LV MC NL PL PT RO SE SI SK TR

(30) Priority: **28.11.2005 US 164506**

(43) Date of publication of application:
10.08.2016 Bulletin 2016/32

(62) Document number(s) of the earlier application(s) in accordance with Art. 76 EPC:
08157250.5 / 1 956 806
06819634.4 / 1 955 529

(73) Proprietor: **SnapTrack, Inc.**
San Diego, CA 92121 (US)

(72) Inventors:
• **SANDELL, Philip**
217 71 Malmö (SE)
• **WILLSTEDT, Lotta**
234 35 Lomma (SE)

(74) Representative: **Zacco Sweden AB**
P.O. Box 5581
114 85 Stockholm (SE)

(56) References cited:
EP-A- 1 394 666 EP-A- 1 603 312
EP-A2- 0 946 028 EP-A2- 1 104 151
JP-A- 2005 244 468

EP 3 054 658 B1

Note: Within nine months of the publication of the mention of the grant of the European patent in the European Patent Bulletin, any person may give notice to the European Patent Office of opposition to that patent, in accordance with the Implementing Regulations. Notice of opposition shall not be deemed to have been filed until the opposition fee has been paid. (Art. 99(1) European Patent Convention).

DescriptionField of the invention

[0001] The present invention relates to communication terminals capable of using different communication channels for communication with a remote party defined by a communication address, and a method for initiating a communication link to such a remote party. The terminal comprises a user interface, including a display and an input interface, and the terminal is devised to display a selectable set of communication channels responsive to sensing input of letters. The invention thereby offers an advantage in terms of handling for users who more or less frequently use different communication channels for communicating with a certain party, such as both voice dialing and text messaging.

Background

[0002] Early communication methods and devices where dedicated to one type of communication channel, such as the telegraph and subsequently the telephone. Mobile telephony was originally developed and used for voice dialing. With the second generation of mobile communications, the possibility of sending brief text messages was provided, so called SMS (Short Message Service). SMS enables short messages of generally no more than 140-160 characters in length to be sent and transmitted from a mobile phone, which was introduced in the GSM (Global System for Mobile communications) system and later supported by all other digital-based mobile communications systems. Later, an enhanced transmission service called MMS (Multimedia Messaging Service) was provided, enabling graphics, video clips and sound files to be transmitted via mobile phones. Developed as part of the 3GPP project, MMS phones are generally backward compatible with SMS.

[0003] Today, many users of mobile communication systems use their mobile phones for text messaging just as much as for voice dialing. However, the user interfaces of most mobile phones are still configured to be used mainly for dialing, and it takes some maneuvering to initiate a text message when the mobile phone is in a stand-by mode. Typically, if a telephone number is input by means of the user input interface or fetched from a contact list in the phone, an ordinary speech communication link will be setup upon making a call command. If, on the other hand, the user would like to send a text message, this communication channel has to be selected first.

[0004] EP 1 394 666 discloses an information input device in a portable phone, in which a display screen displays options and a cursor. For selection of a desired option from the display screen, for example, sending a phone call or an electronic mail, a cursor is moved to a phone number and placed over it, whereby sending of the phone call or electronic mail to a phone of that selected number.

Summary of the invention

[0005] An object of the invention is to provide a more efficient solution for initiating a communication session in a communication terminal, capable of communication over a plurality of different communication channels as defined in independent claims 1 and 8. Further, preferred features may be found in dependent claims.

10 Brief description of the drawings

[0006] The accompanying drawings, which are included to provide further understanding of the invention and are incorporated in and constitute a part of this application, illustrate certain embodiments of the invention. In the drawings:

20 Fig. 1 schematically illustrates a communication terminal with a display and a user input interface, configured to operate in accordance with an exemplary embodiment of the invention;

25 Fig. 2 illustrates the display of the terminal of Fig. 1, after selection of communication channel in accordance with an exemplary embodiment of the invention;

30 Fig. 3 illustrates an alternative layout of the display of the terminal of Fig. 1, in accordance with an exemplary embodiment of the invention;

35 Fig. 4 illustrates the display of the terminal of Fig. 1, further devised to present information associated with an input address number in accordance with an exemplary embodiment of the invention;

40 Fig. 5 illustrates the display of the terminal of Fig. 1, further devised to present communication address information upon input of a speed dial number in accordance with an exemplary embodiment of the invention; and

45 Fig. 6 schematically illustrates a block diagram representing a communication terminal configured in accordance with an embodiment of the invention.

Detailed description of exemplary and preferred embodiments

50 **[0007]** Exemplary embodiments of the present invention will be described more fully hereinafter with reference to the accompanying drawings, in which exemplary embodiments of the invention are shown. This invention may, however, be embodied in many different forms and should not be construed as limited to the exemplary embodiments set forth herein. Rather, these exemplary embodiments are provided so that this disclosure will be thorough and complete, and will fully convey the scope of the invention to those skilled in the art. Like numbers refer to like elements throughout.

55 **[0008]** The terminology used herein is for the purpose of describing particular exemplary embodiments only and is not intended to be limiting of the invention. As used

herein, the singular forms "a", "an" and "the" are intended to include the plural forms as well, unless the context clearly indicates otherwise. It will be further understood that the terms "comprises" "comprising," "includes" and/or "including" when used herein, specify the presence of stated features, integers, steps, operations, elements, and/or components, but do not preclude the presence or addition of one or more other features, integers, steps, operations, elements, components, and/or groups thereof.

[0009] Unless otherwise defined, all terms (including technical and scientific terms) used herein have the same meaning as commonly understood by one of ordinary skill in the art to which this invention belongs. It will be further understood that terms used herein should be interpreted as having a meaning that is consistent with their meaning in the context of this specification and the relevant art and will not be interpreted in an idealized or overly formal sense unless expressly so defined herein.

[0010] The present invention is described below with reference to block diagrams and/or flowchart illustrations of methods, apparatus (systems) and/or computer program products according to embodiments of the invention. It is understood that several blocks of the block diagrams and/or flowchart illustrations, and combinations of blocks in the block diagrams and/or flowchart illustrations, can be implemented by computer program instructions. These computer program instructions may be provided to a processor of a general purpose computer, special purpose computer, and/or other programmable data processing apparatus to produce a machine, such that the instructions, which execute via the processor of the computer and/or other programmable data processing apparatus, create means for implementing the functions/acts specified in the block diagrams and/or flowchart block or blocks.

[0011] These computer program instructions may also be stored in a computer-readable memory that can direct a computer or other programmable data processing apparatus to function in a particular manner, such that the instructions stored in the computer-readable memory produce an article of manufacture including instructions which implement the function/act specified in the block diagrams and/or flowchart block or blocks.

[0012] The computer program instructions may also be loaded onto a computer or other programmable data processing apparatus to cause a series of operational steps to be performed on the computer or other programmable apparatus to produce a computer-implemented process such that the instructions which execute on the computer or other programmable apparatus provide steps for implementing the functions/acts specified in the block diagrams and/or flowchart block or blocks.

[0013] Accordingly, the present invention may be embodied in hardware and/or in software (including firmware, resident software, micro-code, etc.). Furthermore, the present invention may take the form of a computer program product on a computer-usable or compu-

ter-readable storage medium having computer-usable or computer-readable program code embodied in the medium for use by or in connection with an instruction execution system. In the context of this document, a computer-usable or computer-readable medium may be any medium that can contain, store, communicate, propagate, or transport the program for use by or in connection with the instruction execution system, apparatus, or device.

[0014] The computer-usable or computer-readable medium may be, for example but not limited to, an electronic, magnetic, optical, electromagnetic, infrared, or semiconductor system, apparatus, device, or propagation medium. More specific examples (a non-exhaustive list) of the computer-readable medium would include the following: an electrical connection having one or more wires, a portable computer diskette, a random access memory (RAM), a read-only memory (ROM), an erasable programmable read-only memory (EPROM or Flash memory), an optical fiber, and a portable compact disc read-only memory (CD-ROM). Note that the computer-usable or computer-readable medium could even be paper or another suitable medium upon which the program is printed, as the program can be electronically captured, via, for instance, optical scanning of the paper or other medium, then compiled, interpreted, or otherwise processed in a suitable manner, if necessary, and then stored in a computer memory.

[0015] Fig. 1 shows an example of a communication terminal in which the present invention may be applied, in this case in the exemplary embodiment of a portable communication terminal 10, such as a mobile phone. A basis for the invention is that the communication terminal 10 is capable of communicating through at least two different types of communication channels. The term portable communication terminal includes all mobile equipment devised for radio communication with a radio station, which radio station may also be a mobile terminal or for instance a stationary base station. Consequently, the term portable communication terminal includes any mobile phones, communicators, electronic organizers, smart phones, PDA:s (Personal Digital Assistance), vehicle-mounted radio communication devices or the like as well as portable laptop computers devised for wireless communication in for instance a WLAN (Wireless Local Area Network). It should also be noted that the invention is, as such, in no way related to the portability of the communication terminal, nor that the terminal is devised for wireless communication. The communication terminal may thus be a stationary wire-connected communication terminal, capable of communicating through at least two different types of communication channels.

[0016] The terminal 10 of Fig. 1 comprises a chassis or housing 11, carrying a user audio input in the form of a microphone 12 and a user audio output in the form of a speaker 13 or a connection to an ear piece (not shown). A set of keys, buttons or the like constitutes an input interface 14, usable for instance for dialing according to

the established art. A data output interface comprises a display 15 devised to present communication information to a terminal user, preferably by use of a graphical user interface. The terminal further includes radio transmitter and receiver means and an antenna (not shown) for conveying radio signals. In order to provide power to the terminal, a battery (not shown) is either included in or releasably attachable to the terminal 10. Fig. 1 illustrates the most traditional type of mobile phones, which is in one piece and has physical keys in the input interface 14. Alternative solutions, which may also be used in a terminal devised in accordance with the present invention, includes clamshell type phones, jack knife phones, phones with slide covers or flip-up covers, and so on. Furthermore, the input interface 14 may comprise a touch-sensitive display, such as display 15.

[0017] As mentioned, mobile phones were originally developed to support phone calls, and that was it. Over time more and more functions have been built in to the devices and today a mobile phone can support a number of other tasks than just phone calls. But still today phone call is the main functionality of a mobile phone, and it will probably remain so for a period of time. The focus on the function "phone call" is therefore obvious when start typing numbers on a mobile phone, and the only function available is to call that dialled number. However, other communication channels except phone calls are used heavily by the users, for example sending text messages.

[0018] The present invention is built on the fact that other communication channels in some situations might be as important as phone call, and hence should be easily accessible from the mobile phone's standby screen. In the standby screen of many mobile phones of today, the only function that the user is offered is to call the typed number. To initiate a communication link through another communication channel with a contact or number, the user will have to navigate to desired function, such as SMS, MMS, Instant messaging, email etc, or select a number from the contact list and select a function from there. With this state of the art solution the user is forced to either populate the contact list or use the wizard style UI where the user for example first types the message then enters an address number for the recipient.

[0019] According to an exemplary embodiment of the invention, all registered communication channels in the communication terminal are presented in combination with the number input in Standby screen. Once the user starts to type numbers the different communications channels are presented and will be selectable. The user will, in addition to initiating a phone call, be able to initiate e.g. a text message, email, video call, an instant messaging session etc, directly after typing the phone number. The communication channels are presented as selectable items, e.g. in the form of separate text portions, or even more preferred as individual icons, one for each communication channel. Preferably, a default channel is preset, such as normal phone call. When typing of an address number is sensed the selectable items are then

presented, of which the default channel is pre-selected. If a user generally prefers another communication channel than the default channel, which may be normal phone call, the default channel can be changed, e.g. to video call or text messaging.

[0020] Fig. 1 illustrates visual parts of a terminal 10, whereas Fig. 6 illustrates functional elements of terminal 10 arranged as a block diagram. It should be noted that these functional elements need not be physically divided in the way indicated in Fig. 6, and that the block diagram of Fig. 6 is meant to more clearly illustrate the functional steps carried out in the terminal.

[0021] In Fig. 6, a control unit 60 is schematically illustrated in terminal 10. Control unit 60 preferably includes a microprocessor with associated memory space, operation system and application software, and is operable to handle communication and data transfer between sub-units within the terminal. An input detection device 61 is connected to input interface 14, and configured to sense input of i.e an address number. In an exemplary embodiment, an address number may be input using input interface 14 to type the number, or by fetching the number in a contact list stored in the terminal using e.g. a navigation tool 141 of the input interface. A display control device 62 is provided to display information and images on display 15, by means of a graphical user interface. Furthermore, display control device 62 is responsive to present information on display 15 responsive to the input detection device 61 sensing input of an address number, as will be explained. A communication controller 63 includes a transceiver device for transmitting and possibly receiving communication signals through a communication interface. In the presented embodiment, in which terminal 10 is a mobile phone, communication controller 63 includes digital signal coding and encoding means and a radio transceiver, and is operable to communicate with other parties by radio using an antenna 64. Alternative solutions make use of a wire-bound communication interface and electric signals rather than radio. Transmitted and received signals may be circuit-switched or packet-switched. Communication controller 63 is thus operable to e.g. initiate a call, or to send a message. A data retrieving mechanism 65 is operable to browse or retrieve data from a memory 66. The data retrieving mechanism 65 and memory 66 will be referred to in general terms below for different type of data, but it should be understood that different elements, software and data memories may be used for different types of stored data. According to an exemplary embodiment of Fig. 1, a user has input an address number in the form of a telephone number +123456789, either using input interface 14 to type the number or by fetching the number in a contact list stored in the terminal. The input address number is presented in a typing frame 151 on display 15. Upon input of the address number, display control device 62 is configured to present, on display 15, selectable items 152-157 representing a plurality of different communication channels. Selectable items 152-157 are merely ex-

amples, and represent phone call 152, text message 153, video call 154, instant messaging 155, email 156, and MMS 157. Preferably, and as illustrated, the selectable items are presented as icons, designed to visually indicate the communication channel they represent. Additionally, a written explanation 158 may be presented for a currently marked item. An alternative solution is to present all selectable items in clear text, e.g. in a column. In a preferred embodiment, the selectable items are presented as soon as a first character is typed. In another exemplary embodiment, the selectable items are presented only after a full number has been typed. It may be noted that not all communication channels shown in Fig. 1 are by necessity usable by means of one and the same address number, but at least voice call 152, text messaging, such as SMS, 153, video call 154 and MMS 157, can all be setup using a telephone number to a mobile phone capable of handling these services. In one embodiment, all registered communication channels usable within terminal 10 are presented on display 15. In another embodiment, data retrieving mechanism 65 is configured to enter a contact list stored in memory 66, using the input address number, and thereby retrieve information about which communication channels are usable for communicating with a recipient having the input address number. This way, it may be possible to type a persons phone number, upon which terminal 10 recognizes that phone number and establishes that there is also e.g. an email number linked to that contact. In that case the email item 156 is also presented. If no email address is found tied to that contact, the display control device 62 may be configured not to present the email item 157.

[0022] One exemplary embodiment of the invention therefore relates to a communication terminal 10 comprising a transceiver device 63 for transmitting signals over a communication link, a user interface including a display 15 and an input interface 14, and an input detection device 61 configured to sense input of an address number representing a communication address for a second communication terminal, wherein a display control device 62 is connected to the input detection device, and configured to present a plurality of selectable items 152-157 representing different communication channels on the display, responsive to sensing of input of an address number.

[0023] Fig. 1 illustrates a default setting, according to an exemplary embodiment of the invention. In this default setting, voice call 152 is preset to be the first choice of communication channel. Consequently, as the selectable items 152-157 are presented upon input of the address number, a selection indicator 159 clearly highlights selectable item 152. In the illustrated exemplary embodiment, selection indicator 159 is a frame encompassing the presently selected item. Alternative solutions may be to fade the presently not selected items, to enlarge the selected item compared to the other items, or a combination of these effects. Yet another alternative is to

present only the presently selected item, whereupon operation of navigation key 141 another of the selectable items will show.

[0024] Since voice call is the pre-selected default setting, a voice call communication link to the input address number can be setup by an initiate communication option command, in this case a call command. In Fig. 1 this is exemplified by a softkey button 142 of the input interface, linked to a softkey field 160 on display 15. In the drawings, softkey field 160 is indicated by a dashed frame merely to indicate the presence of the field, whereas in a real embodiment only the text given in the softkey field 160 will generally be visible, not any border frame. As voice call is presently selected in Fig. 1, softkey field 160 states "Call". Activation of the softkey button 142 will then trigger the call. However, if the user wishes to use another communication channel, another selectable item 153-157 representing that channel is selected. This is typically performed by using a navigation tool 141 of the input interface 14, such as a joystick, a jog ball, a set of arrow keys, or the like.

[0025] Function of a communication terminal 10 arranged in accordance with the invention will now be described by reference to Figs 2-6.

[0026] In Fig. 2 the user has operated the navigation tool 141 to instead select text messaging. In one embodiment, as shown in Fig. 2, a clear text explanation 158 is also given on display 15 for the presently selected communication channel. Upon operation of navigation tool 141 to move selection indicator 159 to selection item 153, the text given in softkey field 160 preferably also changes character, from "Call" to "Send to". An alternative wording to be used for softkey field 160 could be "Write to", since at this point no real text message has been entered. Therefore, activation of softkey button 142 preferably triggers presentation of a text input field on display 15. An alternative way to proceed from Fig. 2 may be to activate a get data option using another presented selectable item on display 15. In Fig. 2 this is illustrated by a right softkey field 161 with associated softkey button 143. As for softkey field 160, the border frame around softkey field 161 is merely shown in the drawings to indicate its presence. Softkey field 161 presents a text message "More", activation of which may present a number of different options according to the established art. In one embodiment, an option under "More" may be to retrieve stored message data from a memory 66 using data retrieving mechanism 65, for including the retrieved data in a message addressed to the input address number. This way a message forwarding function is provided. Preferably, the retrieved message data can also be changed before sending. Another usable feature is to present an add recipient option on display 15, selectable to add a communication address for further recipients to which a communication link is to be set up. For text messaging, a retrieved or input text message can this way be transmitted to plural recipients. Typically, such an add recipient option may also be selectable from a menu presented upon

activating the "More" softkey, whereupon data retrieving mechanism 65 is triggered to present a contact list stored in memory 66, from which further recipient address numbers may be selected. A corresponding arrangement regarding retrieving stored data and stored address numbers can be made for MMS and for emails, where retrieval of previous data for sending to another communication terminal, and sending of data to plural recipients, may be of interest.

[0027] After retrieving or inputting text data, or other types of more advanced data such as images, sound files or video clips in the case of MMS or email, the communication link is setup by activation of the initiate communication option, i.e. the "Send to" softkey.

[0028] Fig. 3 schematically illustrates an alternative layout for the selectable items 152-157 on display 15, arranged in a rotatable circle. Operation of navigation tool 141 to the right or left will rotate the circularly arranged items 152-157, such that the foremost, text message in Fig. 3, is illustrated as selected. As before, a selection indicator may also be employed in the form of a frame, and/or a clear text explanation 158 may be provided, to more clearly show which communication channel is presently selected.

[0029] Fig. 4 illustrates another exemplary embodiment of the invention, in which input of an address number which is already present in a contact list in memory 66 also involves retrieving an image 162 and/or an identity 163 for a user defined by the address number in question. The data for the user is retrieved by data retrieving mechanism 65 from memory 66, and is presented on display 15. As mentioned above, sensing that the input address number is already present in a stored contact list may also involve presenting selectable items 152-157 only related to communication channels usable for setting up a communication link to the recipient in question. As an example, an address number in the form of a telephone number is input by typing. The number is recognized using data retrieving mechanism, which transparently checks the stored contact list. An email address linked to a user having the input telephone number is thereby found, whereupon the email item 156 is shown on display 15 along with the other items usable for setting up a communication link to the telephone number in question. If navigation tool 141 is operated to select the email item 156, the address number in field 151 may in one embodiment change to show the retrieved email address from the contact list.

[0030] Fig. 5 illustrates another exemplary embodiment of the invention, in which a speed dial function is programmed into the terminal. If a single character address number, 4 in this case, is input by typing and no new character is input for a predetermined period, data retrieving mechanism 65 is devised to check for a corresponding speed dial number in a speed dial number memory 66, and to retrieve a communication address stored in memory 66. In the example of Fig. 5, the corresponding communication address, in this case a tele-

phone number, is thereby presented in clear text on display 15. At the same time, data related to a user associated with the input speed dial number is retrieved and displayed, in the same manner as for the embodiment of Fig. 4.

[0031] The present invention has been described by means of examples in terms of functional steps and different layouts for realizing the invention in various embodiments. The basic idea behind the invention, common for the preferred and exemplary embodiments, is to provide a tool for users where communication channel can be easily selected before setting up a communication link. The invention therefore provides a scheme for initiating a communication link comprising two basic steps.

[0032] In a first step an address number is input. The address number may be a true communication address or a number linked to a communication address which can be recognized as such by the terminal, such as a speed dial number. Another variant is for the terminal software to, upon sensing typing of a number, check for communication addresses starting with those numbers and fill in the typing field 151 automatically, comparable to the state of the art T9 function for text input. The preferred embodiment is to input letters corresponding to a stored title in a contact list, rather than numbers of an address number. Such an embodiment, preferably configured to also sense and recognize numbers, may be used for terminals with more advanced input interfaces than standard mobile phones, with letter key in addition to number keys, such as a pocket computer or a PDA.

[0033] When it is sensed that an address number is input, selection items are presented on the terminal display, for selecting which type of communication channel to use for setting up a communication link. This is particularly beneficial when different types of communication channels are frequently used for communicating from the same terminal, and a typical scenario is a mobile phone used for both voice calls and for SMS and MMS. Using a navigation tool, the communication channel of interest can be selected, after which the communication link can be set up. For a voice call or video call, the setting up of the communication link involves calling the communication address number in question. For messaging, the setting up of a communication link will include entering message data and sending the data to the communication address in question.

[0034] The invention thereby provides a straightforward way of communicating using a terminal capable of handling different communication channels, where handling of the communication link setup process is streamlined to first focus on choice of recipient and then on choice of communication channel by simple selection. Various modifications of the embodiments described herein are foreseeable, whereas the scope of the invention is defined by the appended claims.

Claims

1. A method for initiating a communication link from a first communication terminal (10) to a second communication terminal, comprising the steps of:
- 5 sensing input of letters that are input by a user in the first communication terminal (10), representing a title for the second communication terminal;
- 10 retrieving information associated with the title of the second communication terminal;
- presenting the retrieved information on a display of the first communication terminal (10);
- 15 retrieving information related to selectable communication channels usable for communication with second communication terminal; and
- presenting, on the display of the first communication terminal (10), a plurality of selectable items (152-157) only representing the usable communication channels, responsive to sensing input of a title;
- 20 wherein, once the input of letters by the user is sensed, the different usable communications channels are presented for selection.
- 25
2. The method according to claim 1, comprising the step of:
- 30 setting up a communication link to the second communication terminal through a selected one of the plurality of communication channels.
3. The method according to claim 1, comprising the step of:
- 35 sensing input of a command, selecting one of the communication channels.
4. The method according to claim 1, comprising the step of:
- 40 presenting the plurality of selectable items (152-157) as separate icons.
- 45
5. The method according to claim 1, wherein the different communication channels include any two types within the group of: voice call, video call, text messaging, picture messaging and email.
- 50
6. The method according to claim 1, wherein the retrieved information includes identity data of a user of the second communication terminal.
7. The method according to claim 1, wherein the retrieved information includes a picture of a user of the second communication terminal.
- 55
8. A communication terminal (10) comprising:
- a communication controller (63) including a transceiver device for transmitting signals over a communication link;
- a user interface including a display and an input interface;
- an input detection device (61) configured to sense input of letters that are input by a user representing a title for a second communication terminal;
- a title memory;
- a data retrieving mechanism (65), configured to retrieve information associated with the title of the second communication terminal and connected to a display control device (62) for presenting the retrieved information on the display and
- the data retrieving mechanism (65) is configured to retrieve information related to selectable communication channels usable for communicating with the second communication terminal;
- characterised in that** the display control device (62) is configured to present, on the display, a plurality of selectable items (152-157) only representing the usable communication channels, responsive to sensing of input of the title, wherein, once the input of letters by the user is sensed, the different usable communications channels are presented for selection.
9. The communication terminal (10) according to claim 8, wherein the communication controller (63) is configured to set up a communication link to the second communication terminal through a selected one of the plurality of communication channels.
10. The communication terminal (10) according to claim 8, wherein the input detection device (61) is configured to sense input of a command, selecting one of the communication channels.
11. The communication terminal (10) according to claim 8, wherein the display control device (62) is configured to present the plurality of selectable items (152-157) as separate icons.
12. The communication terminal (10) according to claim 8, wherein the different communication channels include any two types within the group of: voice call, video call, text messaging, picture messaging and email.
13. The communication terminal (10) according to claim 8, wherein the retrieved information includes identity data of a user of the second communication terminal.
14. The communication terminal (10) according to claim

8, wherein the retrieved information includes a picture (162) of a user of the second communication terminal.

Patentansprüche

1. Verfahren zur Initiierung einer Kommunikationsverbindung von einem ersten Kommunikationsendgerät (10) zu einem zweiten Kommunikationsendgerät, umfassend die folgenden Schritte:

Detektieren einer Eingabe von Buchstaben, die durch einen Benutzer in das erste Kommunikationsendgerät (10) eingegeben wird und einen Titel für das zweite Kommunikationsendgerät repräsentiert;

Abfragen von Information, die mit dem Titel des zweiten Kommunikationsendgeräts assoziiert ist;

Darstellen der abgefragten Information auf einer Anzeige des ersten Kommunikationsendgeräts (10);

Abfragen von Information, die sich auf auswählbare Kommunikationskanäle bezieht, die für Kommunikation mit dem zweiten Kommunikationsendgerät verwendbar sind; und

Darstellen, auf der Anzeige des ersten Kommunikationsendgeräts (10), einer Mehrzahl von auswählbaren Punkten (152-157), die lediglich die verwendbaren Kommunikationskanäle repräsentieren, als Antwort auf ein Detektieren der Eingabe eines Titels;

wobei die verschiedenen verwendbaren Kommunikationskanäle zur Auswahl dargestellt werden, wenn die Eingabe von Buchstaben durch den Benutzer detektiert worden ist.

2. Verfahren nach Anspruch 1, umfassend den folgenden Schritt:

Aufbau einer Kommunikationsverbindung mit dem zweiten Kommunikationsendgerät über einen ausgewählten aus der Mehrzahl von Kommunikationskanälen.

3. Verfahren nach Anspruch 1, umfassend den folgenden Schritt:

Detektieren einer Eingabe eines Befehls, Auswählen von einem der Kommunikationskanäle.

4. Verfahren nach Anspruch 1, umfassend den folgenden Schritt:

Darstellen der Mehrzahl auswählbarer Punkte (152-157) als einzelne Ikonen.

5. Verfahren nach Anspruch 1, wobei die verschiedenen Kommunikationskanäle zwei Typen der Gruppe: Sprachanruf, Videoanruf, Textnachrichten, Bildnachrichten und E-Mail umfassen.

5

6. Verfahren nach Anspruch 1, wobei die abgefragte Information Identitätsdaten eines Benutzers des zweiten Kommunikationsendgeräts umfasst.

10

7. Verfahren nach Anspruch 1, wobei die abgefragte Information ein Bild eines Benutzers des zweiten Kommunikationsendgeräts umfasst.

15

8. Kommunikationsendgerät (10) umfassend:

eine Kommunikationssteuervorrichtung (63) umfassend eine Transceivervorrichtung zur Übertragung von Signalen über eine Kommunikationsverbindung;

eine Benutzerschnittstelle umfassend eine Anzeige und eine Eingabeschnittstelle;

eine Eingabedetektiervorrichtung (61), die dazu ausgebildet ist, die Eingabe von Buchstaben, die durch einen Benutzer eingegeben wird und einen Titel für ein zweites Kommunikationsendgerät repräsentiert, zu detektieren;

einen Titelspeicher;

einen Datenabfragemechanismus (65), der dazu ausgebildet ist, Information abzufragen, die mit dem Titel des zweiten Kommunikationsendgeräts assoziiert ist und mit einer Anzeigesteuervorrichtung (62) zur Darstellung der abgefragten Information auf der Anzeige verbunden ist; und

der Datenabfragemechanismus (65) dazu ausgebildet ist, Information abzufragen, die sich auf auswählbare Kommunikationskanäle bezieht, die zur Kommunikation mit dem zweiten Kommunikationsendgerät verwendbar sind;

dadurch gekennzeichnet, dass die Anzeigesteuervorrichtung (62) dazu ausgebildet ist, eine Mehrzahl von auswählbaren Punkten (152-157) auf der Anzeige darzustellen, die lediglich die verwendbaren Kommunikationskanäle repräsentieren, als Antwort auf das Detektieren der Eingabe des Titels, wobei die verschiedenen verwendbaren Kommunikationskanäle zur Auswahl dargestellt sind, wenn die Eingabe von Buchstaben durch den Benutzer detektiert worden ist.

40

45

50

9. Kommunikationsendgerät (10) nach Anspruch 8, wobei die Kommunikationssteuervorrichtung (63) zum Aufbau einer Kommunikationsverbindung mit dem zweiten Kommunikationsendgerät über einen ausgewählten aus der Mehrzahl von Kommunikationskanälen ausgebildet ist.

55

10. Kommunikationsendgerät (10) nach Anspruch 8, wobei die Eingabedetektionsvorrichtung (61) dazu ausgebildet ist, die Eingabe eines Befehls zu detektieren, indem einer der Kommunikationskanäle ausgewählt wird. 5
11. Kommunikationsendgerät (10) nach Anspruch 8, wobei die Anzeigesteuervorrichtung (62) zur Darstellung der Mehrzahl von auswählbaren Punkten (152-157) als einzelne Ikonen ausgebildet ist. 10
12. Kommunikationsendgerät (10) nach Anspruch 8, wobei die verschiedenen Kommunikationskanäle zwei Typen der Gruppe: Sprachanruf, Videoanruf, Textnachrichten, Bildnachrichten und E-Mail umfassen. 15
13. Kommunikationsendgerät (10) nach Anspruch 8, wobei die abgefragte Information Identitätsdaten eines Benutzers des zweiten Kommunikationsendgeräts umfasst. 20
14. Kommunikationsendgerät (10) nach Anspruch 8, wobei die abgefragte Information ein Bild (162) eines Benutzers des zweiten Kommunikationsendgeräts umfasst. 25

Revendications

1. Procédé de déclenchement d'une liaison de communication d'un premier terminal de communication (10) à un second terminal de communication, comprenant les étapes consistant à : 30
- détecter une entrée de lettres qui sont entrées par un utilisateur dans le premier terminal de communication (10), représentant un titre pour le second terminal de communication ;
- recupérer des informations associées au titre du second terminal de communication ; 40
- présenter les informations récupérées sur un affichage du premier terminal de communication (10) ;
- recupérer des informations se rapportant à des canaux de communication sélectionnables utilisables pour une communication avec le second terminal de communication ; et 45
- présenter, sur l'affichage du premier terminal de communication (10), une pluralité d'éléments sélectionnables (152-157) représentant uniquement les canaux de communication utilisables, en réponse à la détection d'entrée d'un titre ; 50
- dans lequel, une fois que l'entrée de lettres par l'utilisateur est détectée, les différents canaux de communication utilisables sont présentés pour sélection. 55
2. Procédé selon la revendication 1, comprenant l'étape consistant à :
- configurer une liaison de communication vers le second terminal de communication par le biais d'un canal sélectionné de la pluralité de canaux de communication.
3. Procédé selon la revendication 1, comprenant l'étape consistant à :
- détecter l'entrée d'une commande, sélectionnant un des canaux de communication.
4. Procédé selon la revendication 1, comprenant l'étape consistant à :
- présenter la pluralité d'éléments sélectionnables (152-157) en tant qu'icônes indépendantes.
5. Procédé selon la revendication 1, dans lequel les différents canaux de communication comprennent deux types quelconques au sein du groupe suivant : appel vocal, appel vidéo, messagerie textuelle, messagerie image et courrier électronique.
6. Procédé selon la revendication 1, dans lequel les informations récupérées comprennent des données d'identité d'un utilisateur du second terminal de communication.
7. Procédé selon la revendication 1, dans lequel les informations récupérées comprennent une image d'un utilisateur du second terminal de communication.
8. Terminal de communication (10) comprenant :
- un contrôleur de communication (63) comprenant un dispositif émetteur-récepteur pour transmettre des signaux sur une liaison de communication ;
- une interface utilisateur comprenant un affichage et une interface d'entrée ;
- un dispositif de détection d'entrée (61) configuré pour détecter une entrée de lettres qui sont entrées par un utilisateur représentant un titre pour un second terminal de communication ;
- une mémoire de titre ;
- un mécanisme de récupération de données (65), configuré pour récupérer des informations associées au titre du second terminal de communication et connecté à un dispositif de commande d'affichage (62) pour présenter les informations récupérées sur l'affichage et le mécanisme de récupération de données (65) est configuré pour récupérer des informations

se rapportant à des canaux de communication sélectionnables utilisables pour communiquer avec le second terminal de communication ;

caractérisé en ce que le dispositif de commande d'affichage (62) est configuré pour présenter, sur l'affichage, une pluralité d'éléments sélectionnables (152-157) représentant uniquement les canaux de communication utilisables, en réponse à la détection de la saisie du titre, dans lequel, une fois que la saisie de lettres par l'utilisateur est détectée, les différents canaux de communication utilisables sont présentés pour sélection.

- 5
- 10
- 15
- 20
- 25
- 30
- 35
- 40
- 45
- 50
- 55
9. Terminal de communication (10) selon la revendication 8, dans lequel le contrôleur de communication (63) est conçu pour configurer une liaison de communication vers le second terminal de communication par le biais d'un canal sélectionné de la pluralité de canaux de communication.
 10. Terminal de communication (10) selon la revendication 8, dans lequel le dispositif de détection d'entrée (61) est configuré pour détecter l'entrée d'une commande, sélectionnant un des canaux de communication.
 11. Terminal de communication (10) selon la revendication 8, dans lequel le dispositif de commande d'affichage (62) est configuré pour présenter la pluralité d'éléments sélectionnables (152-157) en tant qu'icônes indépendantes.
 12. Terminal de communication (10) selon la revendication 8, dans lequel les différents canaux de communication comprennent deux types quelconques au sein du groupe suivant : appel vocal, appel vidéo, messagerie textuelle, messagerie image et courrier électronique.
 13. Terminal de communication (10) selon la revendication 8, dans lequel les informations récupérées comprennent des données d'identité d'un utilisateur du second terminal de communication.
 14. Terminal de communication (10) selon la revendication 8, dans lequel les informations récupérées comprennent une image (162) d'un utilisateur du second terminal de communication.

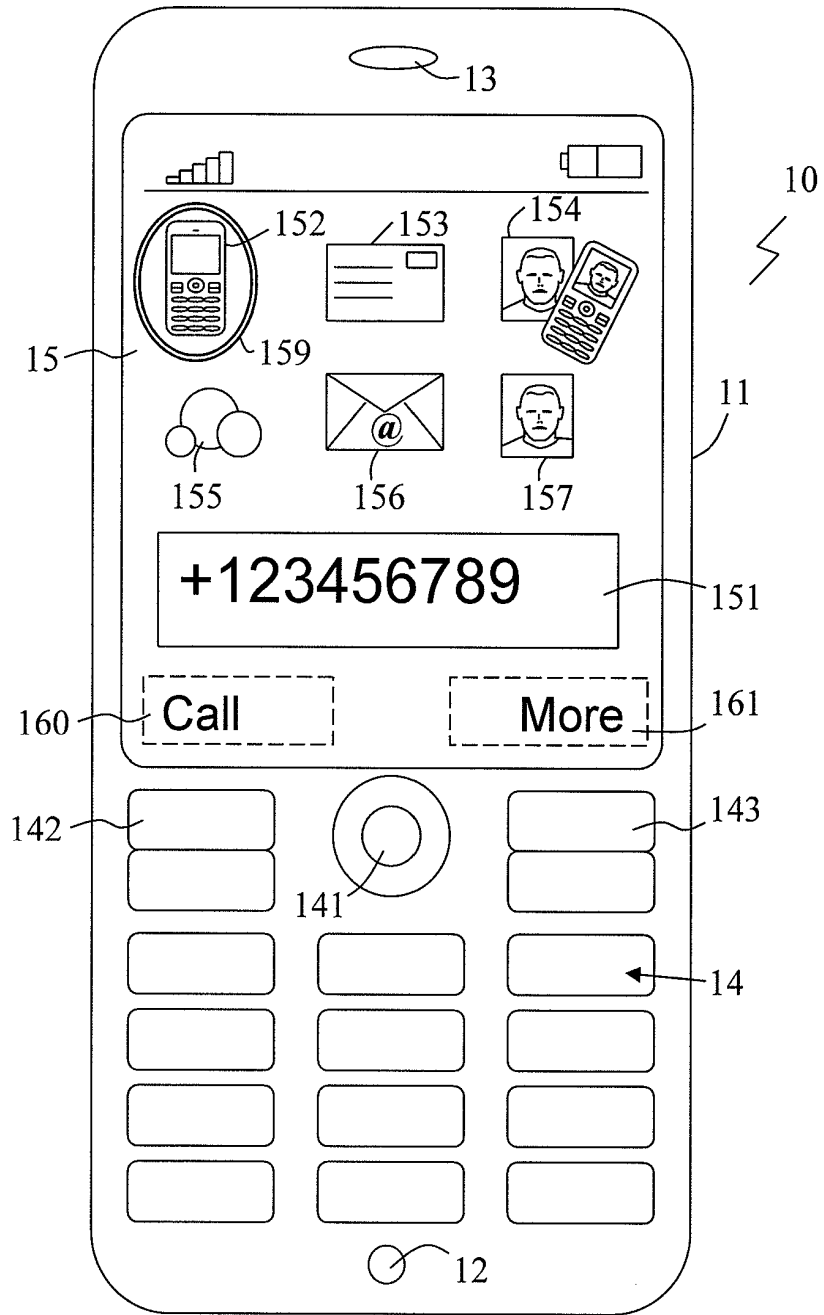
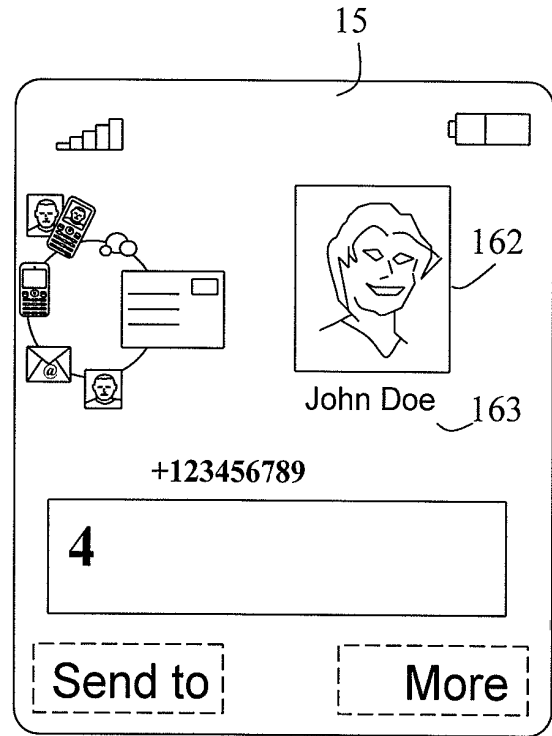
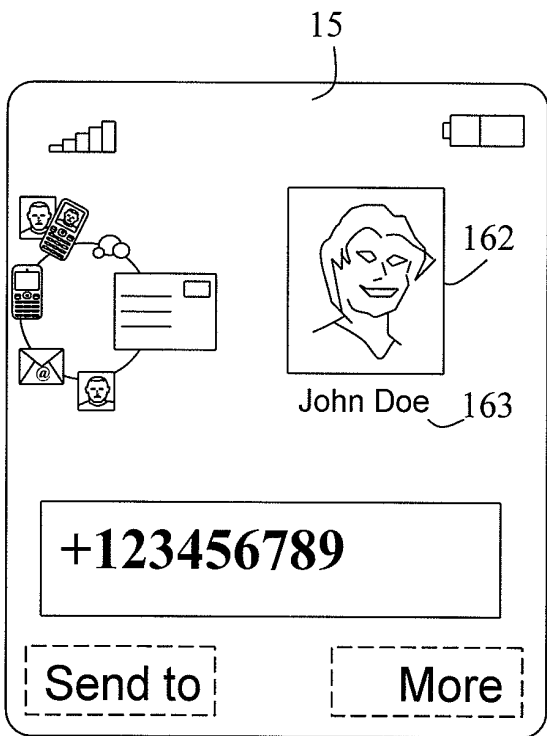
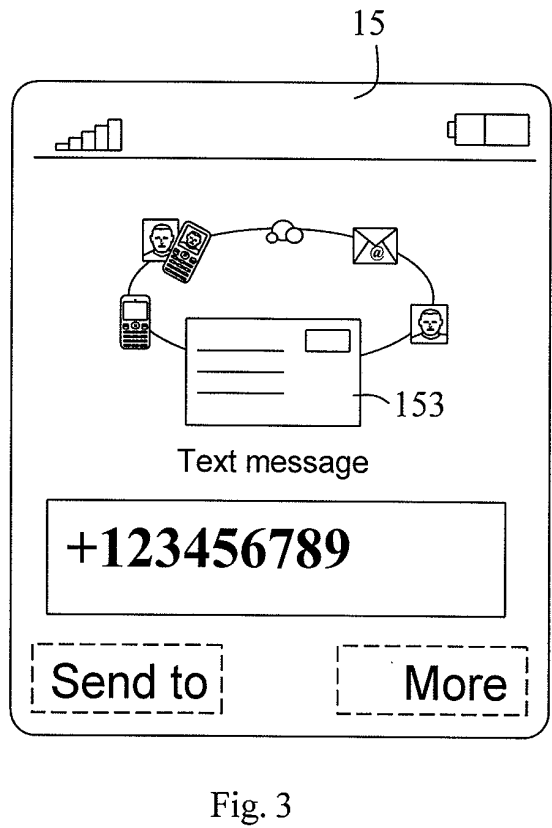
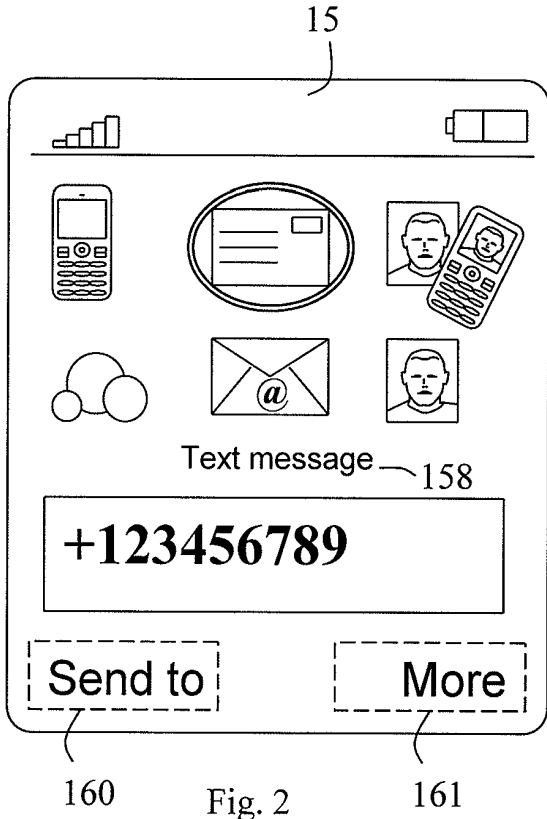

Fig. 1



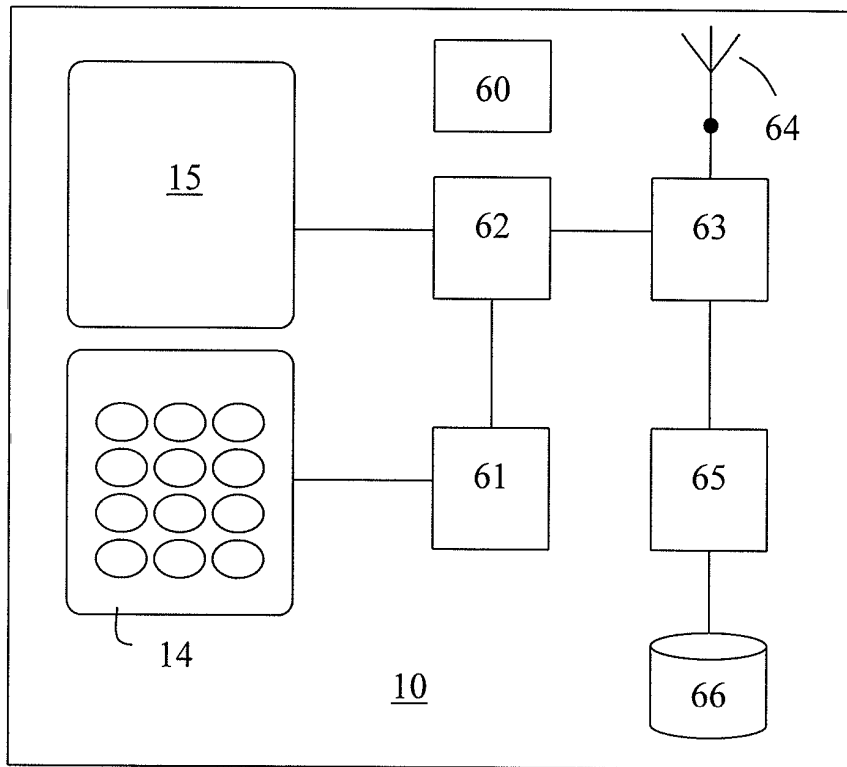

Fig. 6

REFERENCES CITED IN THE DESCRIPTION

This list of references cited by the applicant is for the reader's convenience only. It does not form part of the European patent document. Even though great care has been taken in compiling the references, errors or omissions cannot be excluded and the EPO disclaims all liability in this regard.

Patent documents cited in the description

- EP 1394666 A [0004]