

Aug. 4, 1953

J. T. RANDALL ET AL  
MAGNETRON

2,648,028

Filed Sept. 17, 1947

3 Sheets-Sheet 1

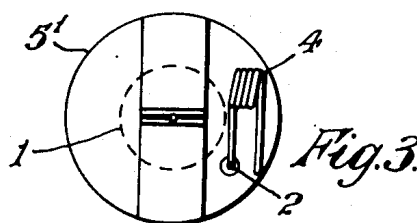
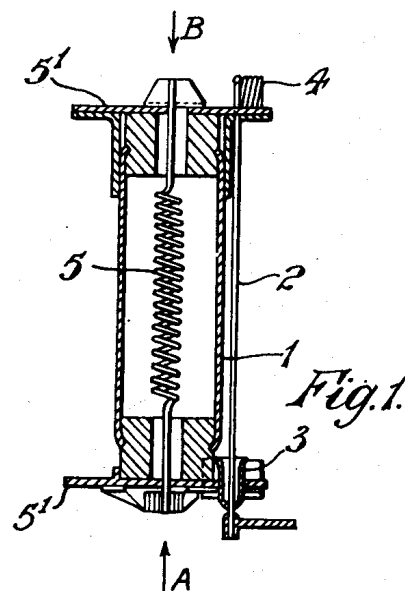
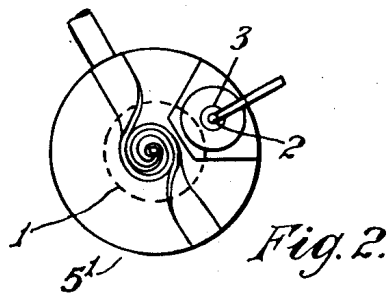

INVENTORS:  
J. T. Randall  
H. A. H. Boot

BY

Nelson D. Moore  
ATTORNEY

Aug. 4, 1953

J. T. RANDALL ET AL

2,648,028

MAGNETRON

Filed Sept. 17, 1947

3 Sheets-Sheet 2

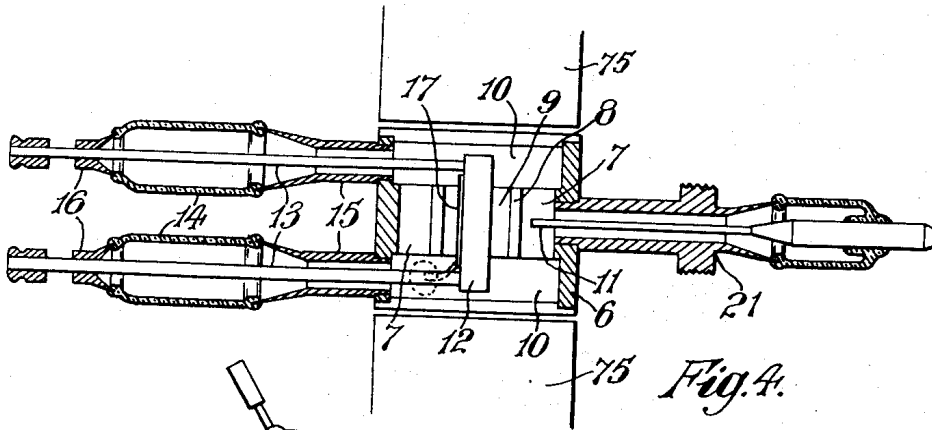

Fig. 4.

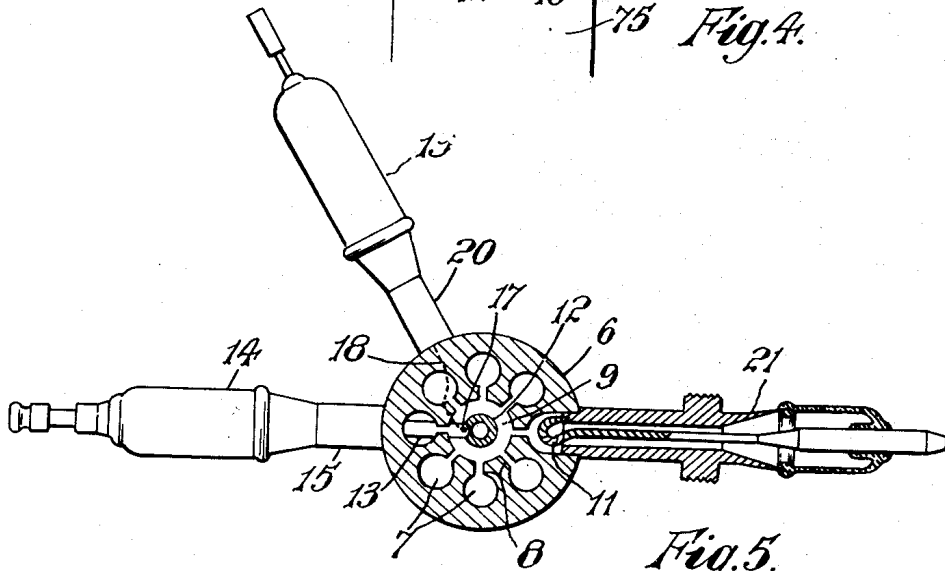

Fig. 5.

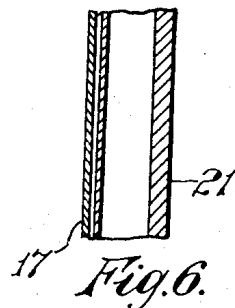

Fig. 6.



Fig. 7.

J. T. Randall  
H. A. Boot

INVENTORS

By *Nelson, M...*  
Attorney.

Aug. 4, 1953

J. T. RANDALL ET AL

2,648,028

Filed Sept. 17, 1947

MAGNETRON

3 Sheets-Sheet 3

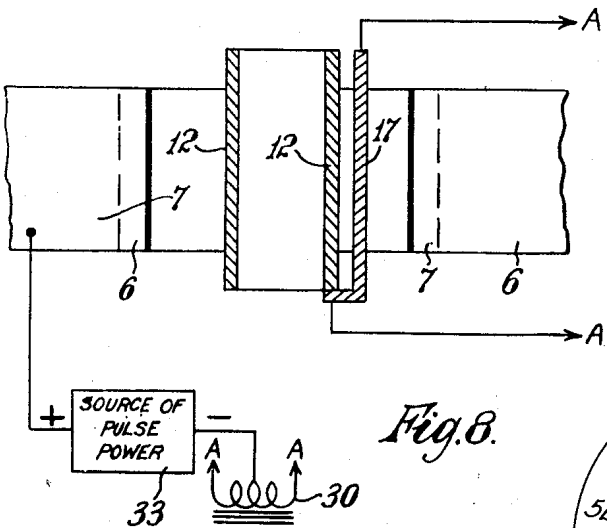

Fig. 8.

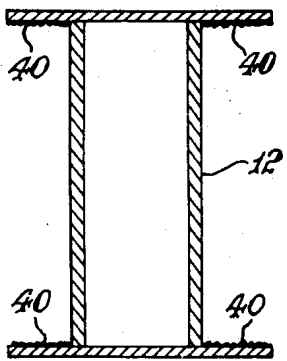

Fig. 9.

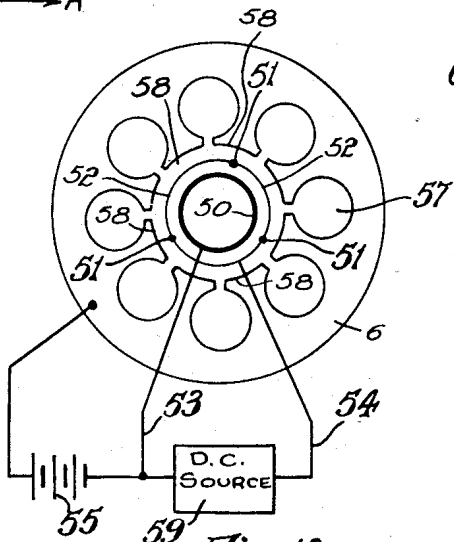

Fig. 10.

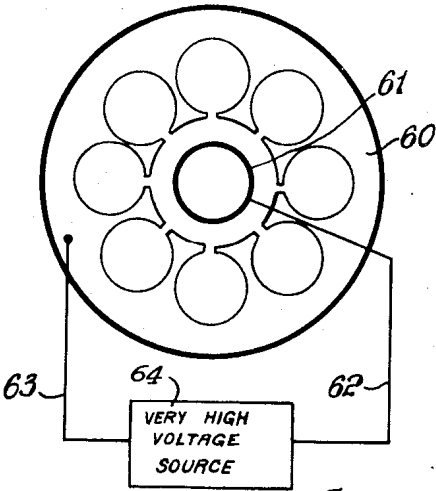

Fig. 11.

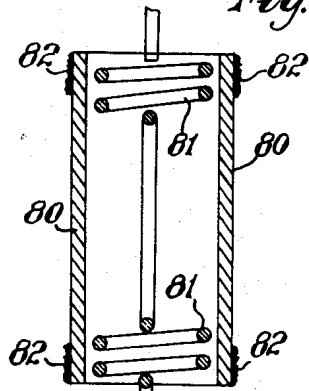

Fig. 12.

INVENTORS  
J. T. Randall  
H. A. H. Scott  
BY *[Signature]*  
ATTORNEY

# UNITED STATES PATENT OFFICE

2,648,028

## MAGNETRON

John Turton Randall, Birmingham, and Henry Albert Howard Boot, London, England, assignors to English Electric Valve Company, Limited, a company of Great Britain and Northern Ireland

Application September 17, 1947, Serial No. 774,596  
In Great Britain August 22, 1941

Section 1, Public Law 690, August 8, 1946  
Patent expires August 22, 1961

15 Claims. (Cl. 315-40)

1

This invention relates to high frequency electrical oscillators and more particularly to oscillators of the magnetron type. We have shown a magnetron type of oscillator in our prior copending application Serial Number 407,680, filed August 20, 1941, now U. S. Patent 2,542,966 granted February 20, 1951, and the present invention is addressed primarily to improvements in the type of oscillator therein disclosed although the invention may be applicable to certain other oscillators. The type of magnetron to which this invention is particularly applicable comprises a metallic anode block having a central cavity with a plurality of resonator cavities around the central cavity and having openings into the central cavity. A cathode is positioned along the axis of the central cavity. The magnetron is particularly useful in pulse-echo systems more commonly known as "radar" systems, although it is applicable to other radio frequency oscillators which emit waves the lengths of which are in the order of a few centimeters. It is often desirable in oscillators operating on the wave lengths referred to, for the power output to be in the form of a series of pulses separated by substantial intervals.

In the magnetrons of the type referred to it has been usual hitherto to make use of the thermionic emission, the cathode being either directly or indirectly heated and having in most cases a suitable coating for the purpose of producing a more powerful emission than would otherwise be obtainable. Now it has been found that in apparatus developing considerable power such cathodes have tended to become over-heated, and this has set a limit to the output powers obtainable. The primary object of the present invention is to overcome this and other disadvantages resulting from the use of thermionic emission, such as the necessity for providing a heater element and its associated circuit, by the provision of an alternative means of obtaining the necessary electronic emission from the cathode. Other objects include the provision of a magnetron that can be conveniently pulsed.

According to the invention, a high frequency electrical oscillator of the specific magnetron type referred to is characterized in that the phenomenon of secondary emission is utilized for the production of the whole or major part of the main electronic stream from the cathode. By "secondary emission" is meant the known effect whereby the bombardment of a surface by an electronic stream results in the emission from this surface of further "secondary" electrons

2

whose number may considerably exceed that of the "primary" or bombarding electrons. The average number of such secondary electrons released by one primary electron is termed the secondary emission coefficient, a factor which varies with the nature of the emitting surface and the velocity and angle of impingement of the bombarding electrons. According to a preferred feature of the invention a certain percentage of the secondary electrons leaving the cathode are caused to return thereto and act as primary or bombarding electrons, the process of secondary emission thereby being maintained.

The essential factors for the production of secondary emission from a cathode in accordance with the invention are: (1) a suitable emitting surface (which may, as hereinafter described, be of a very simple nature), (2) the provision of primary electrons, and (3) the provision of means for bringing about the bombardment of the cathode by the said primary electrons. These factors will be considered in turn.

As regards factor (1), almost any conducting or semi-conducting surface will exhibit the effect, but it has been found that very satisfactory results are obtainable from the use of a thin semi-conducting (e. g. oxide) film on a metallic surface. In such cases the effect is believed to be enhanced by what is known as "thin film field emission" or the Malter effect: the current hypothesis concerning this effect is that secondary emission from the outer surface of the thin semi-conducting film leaves positively charged areas on this surface, and these positive charges, separated from the main conducting surface only by the thickness of the film, produce a powerful field which causes the emission of further electrons therefrom.

Suitable emitting surfaces consist of thin coatings of the oxides of thorium or aluminum on a suitable metallic base. Calcium oxide and the silicates of barium ( $3\text{BaO} \cdot 1\text{SiO}_2$  and  $2\text{BaO} \cdot 1\text{SiO}_2$ ) are also suitable; these substances will also work as primary emitters. Good effects have also been obtained by the use of a metallic cathode coated with the oxides of barium or strontium, such as are used for ordinary thermionic cathodes. A coating of caesium on an emitting surface is known to produce a high secondary emission coefficient, and accordingly such a coating may be employed on a cathode for the purpose of the present invention; a suitable cathode may comprise, for example, a coating of caesium superimposed on a thin oxide film formed on a suitable metallic base.

The choice of the emitting surface employed

3

will depend upon the requirements of individual cases. If, for example, a high emission current is required for a relatively small number of primary or bombarding electrons, it may be desirable to choose a substance such as caesium having a high secondary emission coefficient; if, however, an adequate supply of primary electrons is available, a particularly high secondary emission coefficient is no longer of paramount importance, and it may be preferred to use a substance having a relatively low coefficient of secondary emission provided that this substance has some other quality or qualities which make its use desirable in the particular case in question. Thorium oxide ( $\text{ThO}_2$ ), for example, is particularly suitable in cases where a heavy emission current is required, since it is non-volatile and will, therefore, stand up to a heavy back-bombardment.

The selection of the base material on which the emitting film is deposited is likewise governed by the design considerations of the particular case. Good results have been obtained with aluminum as a base, either in the form of a member of aluminum or a copper member having an aluminum coating formed thereon in known manner. In cases where a heavy current is involved and there is likely to be considerable heating of the cathode it is, however, preferred to use a metal with a high melting point such as molybdenum or tantalum. A thorium oxide coating on a molybdenum base forms a particularly suitable combination, from which a large secondary emission may be obtained at a much lower temperature than if it were used solely as a primary emitter. It will be understood, however, that any of the secondary emission coatings enumerated above may be used with any of the above-mentioned materials or with any other suitable base.

In certain cases the emitting surface may consist of a film of the oxide of the base metal itself, which may then be formed directly on the base. Thus a form of cathode which has been found satisfactory consists of a freshly machined aluminum surface which is cleaned in caustic soda solution and subsequently heated in boiling water to accelerate the formation of a thin oxide film. Beryllium-copper alloys have been found to work as secondary emitters, probably as a result of the formation thereon of a thin film of beryllium oxide.

Regarding the provision of primary electrons, it has already been stated that according to a preferred feature of the invention these are provided by a certain percentage of the secondary electrons which have already left the cathode. It is, however, still necessary to provide primary electrons in the first instance to initiate the secondary emission effect from the cathode when first switching on.

The most efficient means for providing such primary electrons appears to be the use of thermionic emission, either from the main cathode itself (which in this case must be initially heated) or from an auxiliary or "pilot" cathode. When the "pilot" cathode is employed, the usual heater inside the main cathode may be omitted.

Such a pilot cathode may comprise a simple tungsten filament, but it is found that the necessity for keeping such a filament at a sufficiently high temperature to ensure adequate primary emission tends to lead to an erratic life performance. It is preferred, therefore, to use a pilot cathode suitably coated with emitting material so that it will operate at a lower tempera-

4

ture, say  $1500^\circ \text{C.}$ ; this is preferably arranged at a small distance (say 1 mm.) from the main cathode. The oxides of barium or strontium (or thorium oxide used as a primary emitter) form suitable coatings for such a pilot cathode, from which an adequate supply of primary electrons may be obtained to enable relatively heavy secondary emission currents to be produced from the main cathode, even though a comparatively poor secondary emitter is used thereon. It is found that the area of the emitting surface of the pilot cathode is sufficiently small to prevent it from becoming overheated in operation.

As an alternative to the provision of a separate pilot cathode the main cathode may be provided with a heater, and the ends (which are cooler are not so subject to the effects of back bombardment as the central portion) provided with coatings of suitable thermionically emitting material. The coated ends may each occupy roughly a tenth of the total length of the cathode, e. g., 3 mm. at each end of a 3 cm. cylindrical cathode. As a further alternative a directly heated main cathode may be employed, comprising, for example, a wire helix. If desired a heated main cathode may be used in conjunction with a pilot cathode, the function of providing heating means for the main cathode being in this case to effect the "degassing" of the apparatus and/or to provide supplementary thermionic emission as hereinafter described.

An alternative source of free electrons for the initial bombardment of the cathode may be provided by the ionization of any low-pressure gas or vapor within the discharge apparatus when the H. T. supply is switched on, and it appears that even in very hard tubes the minute quantity of residual gas is adequate to produce this effect provided a sufficiently high anode voltage is employed. The disadvantage of this method is the tendency of such residual gas to "clean up" after the apparatus has been in use for some time. As a further alternative a source of ionizing radiation may be arranged either internally or externally with respect to the discharge apparatus; a small quantity of radioactive material may, for example, be provided within the apparatus.

A convenient means for effecting the necessary bombardment of the cathode is provided by the magnetic field which is normally utilized for the operation of the magnetron, the direction of this field being substantially at right angles to the direction at any point of the electrostatic field between the anode and the cathode. It is known that an electron moving in a vacuum and acted on solely by a uniform magnetic field whose direction is at right angles to its plane of motion will theoretically traverse a circular path whose radius is directly proportional to the velocity of the electron; if an electric field is also present, however, the path will take a general curved form whose exact shape depends on the relative strengths and directions of the two fields.

Considering now the free electrons initially produced in apparatus according to the invention by any of the means previously described, it will be seen that under the action of the applied electrostatic field such electrons will commence to move towards the anode; the presence of the magnetic field will, however, cause them to follow curved paths, and some of them will thus strike the cathode. Secondary electrons will thus be released, and of these a certain number (that is, those having a sufficiently small initial velocity) will, under the action of the magnetic

5

field, traverse paths whose curvature is sufficiently great to cause them to return to the cathode. These in turn will cause the release of further secondary electrons, and the secondary emission will thus build up automatically until an equilibrium condition, dependent upon the space charge distribution, is reached. Of the total number of electrons emitted by the cathode a certain percentage thus return to maintain the process of secondary emission, while the remainder constitute the main electron stream required to carry out the function of the apparatus.

The magnetic field may be provided by any suitable permanent magnet, electromagnetic or solenoid arranged either externally or internally with respect to the discharge apparatus. In a simple form the cathode may itself constitute a permanent magnet which provides the necessary field.

As an alternative to the use of a magnetic field for the production of the bombardment effect an electrostatic field may be employed, provided, for example, by a suitable grid or auxiliary electrode to which a steady or alternating potential is applied for the purpose of causing a percentage of the electrons emitted by the cathode to return thereto as described above.

In the operation of a cathode according to the invention the secondary emission effect may be supplemented by thermionic emission, as for example, by the use of a main cathode provided with a heater as described above. Apart from the question of starting up, however, it is not necessary to provide a heater for the purpose of obtaining supplementary thermionic emission from the main cathode, since the necessary temperature may be attained by the normal heating up of the cathode during operation. Since a heating element is not essential in a secondary emission cathode, such a cathode is readily adapted to be air- or water-cooled for the purpose of preventing it from heating up during the operation of the apparatus, or limiting the rise of temperature in the case where a certain amount of heating up is allowed to provide supplementary thermionic emission. The cathode may, for example, consist of a simple metal tube whose exterior may be suitably coated and through which water may be passed for cooling purposes; a copper tube having a coating of aluminum which in turn has a coating of aluminum oxide may conveniently be employed, this construction facilitating the soldering on of copper inlet and outlet tubes.

An important point to observe in connection with a secondary emission cathode having no heater is that it cannot be "degassed" in the normal manner; in high vacuum apparatus the cathode must therefore be kept really cold during operation, e. g., by water cooling, otherwise the apparatus may tend to become "gassy" after a short running period. The alternative is to use a cathode provided with a heater as described; this may either be switched off during operation or kept on to provide supplementary thermionic emission according to circumstances, but in any case the use of secondary emission enables the cathode to be run at a much lower temperature than if thermionic emission alone were employed.

It is contemplated that all of the foregoing cathode arrangements are adapted to be employed in magnetrons which are to be pulsed. In connection with all of the several modifications mentioned above, pulse power is applied to

6

the magnetron; and at the beginning of each pulse, the auxiliary source of electrons starts the flow of primary electrons.

Specific constructions according to the invention will now be described by way of example with reference to the accompanying drawings in which:

Figure 1 is a longitudinal cross-sectional view of a secondary emission cathode suitable for use in a magnetron and provided with a heater and a pilot cathode,

Figures 2 and 3 are end views of the cathode illustrated in Figure 1, looking in the directions of the arrows A and B respectively.

Figures 4 and 5 are respectively a longitudinal cross-sectional view and a medial transverse cross-sectional view of a magnetron according to our said prior copending application and incorporating a water-cooled secondary-emission cathode,

Figures 6 and 7 are fragmentary views (longitudinal and transverse cross-sections respectively) of a water cooled cathode, drawn to a slightly larger scale than the cathode shown in Figures 4 and 5,

Figure 8 is a schematic diagram of the electrical connections employed in connection with the magnetron of Figures 1 to 7 inclusive,

Figure 9 is a cross-sectional view of a cathode such as may be used with our invention, there being also shown a radioactive substance for establishing primary electrons,

Figure 10 is a schematic diagram of a modified form of our invention wherein a screen is employed to cause any free electrons leaving the cathode to return thereto and thereby establish secondary emission,

Figure 11 illustrates a modified form of our invention wherein a very high anode voltage causes ionization of the gas in the tube and thereby establishes primary electrons, and

Figure 12 is a cross-sectional view of a modified form of this invention in which thermionic emission takes place at the ends of the cathode to thereby establish primary electrons.

Referring first to Figures 1 to 3, the cathode shown comprises a molybdenum cylinder 1 having a coating of a suitable secondary emitter such as thorium oxide deposited thereon. The pilot cathode comprises a filament 2, coated with thorium oxide, and arranged parallel with the main cathode and at a distance of the order of 1 mm. from its surface. The filament 2 is mounted in an insulating plug 3 at one end and is secured to a spring 4 at the other end for tensioning purposes. The main cathode is provided with a heater coil 5 for the purpose of degassing and/or the provision of supplementary thermionic emission during operation as previously described. Nickel end shields 5' serve to support the mountings of the heater 5 and the pilot filament 2, and to prevent the passage of stray electrons beyond the ends of the main cathode. The heater 5 may, of course, be omitted entirely when other means of starting flow of primary electrons is employed.

Figures 4 and 5 show a magnetron of the type covered by our said prior copending application. The apparatus comprises a main anode block 6 having a plurality of resonators 7 in the form of cylindrical cavities drilled therein. These resonators have narrow longitudinal gaps 8 opening into a central space 9 in which the cathode is located, and the resonators and the central space open at both ends into end space

10. The output power is transmitted through a coupling loop 11 inserted in one of the resonators.

The secondary emission cathode according to the present invention is of the water cooled type and comprises a hollow cylinder 12 provided with a suitable coating and having copper tubes 13 soldered or otherwise secured to its ends whereby water may be passed through the cathode for cooling purposes. The tubes 13, which also form the cathode connection, pass out laterally through the end spaces 10 of the magnetron, being supported and insulated from the main block 6 by glass tubular members 14 sealed in known manner to copper tubular members 15, 16 which are soldered to the main block 6 (over suitable apertures) and to the tubes 13 respectively.

The pilot cathode of Figures 3 and 4 comprises a filament 17 suitably connected at one end to the main cathode 12 and connected at the other end to a lead 18 which passes out through a glass cap 19 sealed to a copper tubular member 20. A similar copper-glass seal 21 is used for the output lead from the coupling loop 11.

As shown in more detail in Figures 6 and 7 the pilot cathode 17 is inset into a longitudinal depression 22 formed in the surface of the main tubular cathode 12, the wall of which is made sufficiently thick to have the said depression cut therein (as shown) or which may alternatively be indented to form the depression.

Secondary emission cathodes according to the invention are capable of producing high emission currents, and are therefore suitable for use in magnetrons developing considerable power. Moreover, a high space charge density may be formed around the cathode, and this is found in magnetrons of the type referred to above to lead to high efficiencies. A further advantage of the invention resides in the fact that the possibility of eliminating the heater element provides a simpler and more robust construction than is possible with thermionic cathodes, as well as removing a potential source of breakdowns.

Cathodes according to the invention may be of cylindrical, disc or any other form according to requirements.

A main magnet (or other flux producing means) is employed to effect a field parallel to the main cathode in all forms of our invention. In Figure 4 the magnet poles 75 set up the desired field.

Since one of the advantages of the magnetron which we have hereinbefore described is that it is especially suitable for pulse transmitters, we shall proceed to describe one circuit arrangement for so energizing the magnetron as to produce a pulse output. In Figure 8, there is shown the magnetron tube of Figures 1 to 7 inclusive in which the pilot cathode 17 is heated to electron emitting temperature by current from the secondary of filament transformer 30. A source of pulse power 33 has its negative pole connected to the pilot cathode 17 and its positive pole to the anode block 6. The cathode 12 is connected to pilot cathode 17 at one end. The source of pulse power 33 is preferably any device for producing sharp pulses. Alternatively it may be the secondary of a high voltage alternating current transformer in which event it will energize the magnetron on alternate half cycles and thereby produce a modulated wave output. Any other device for producing interrupted continuous waves (I. C. W.) such as for

example a chopper may be employed. In any event when the pulser 33 produces a pulse of the polarities shown on the drawing, the pilot cathode 17 emits electrons which due to the main magnetic field take a curved path and some of them bombard the cold cathode 12 thereby effecting secondary emission. The high potential of the anode 6 causes electrons to leave pilot cathode 17. The field of the main magnet poles 75 deflect the electrons leaving pilot cathode 17 and therefore they do not strike the main cathode 12 solely at one place near the pilot cathode but are distributed about the main cathode 12. The cold cathode 12 is negative with respect to anode 6 and therefore the secondary electrons are emitted initially toward anode 6, however they assume a curved path due to the main magnetic field which is parallel to the axis of cathode 12. The electrons after leaving the cold cathode 12 graze the pole pieces of the anode 6 thus setting up circulating currents in the resonator cavities 7. The loop 11 (see Figure 5) is arranged to transfer the generated power to the antenna circuit. At the conclusion of each pulse initiated by pulser 33, the anode to cathode potential, as well as the potential between the anode 6 and the pilot cathode 17, is stopped thereby stopping generation of further power by the magnetron.

Figure 9 illustrates an alternate system for establishing primary electrons. The cold cathode 12 supports an ionizing element 40 which may be a radium coated element. The inside of tube 12 may form part of a water cooling system.

Figure 10 illustrates still another system for establishing primary electrons. A cold cathode 50 is separated from the anode pole pieces 58. Positioned intermediate the cathode 50 and the pole pieces 58, we locate a screen comprising a series of wires 51 that are parallel to the cold cathode 50. These parallel wires 51 are interconnected by a wire 52. Wires 53 and 54 respectively connect the cold cathode 50 and the screen 51 to a source of current 59 which source may be either steady or alternating. A source of direct current 55 has its negative pole connected to the cold cathode 50 and its positive pole connected to anode block 6. The operation of Figure 10 depends upon the free electrons on the cold cathode 50. These free electrons are attracted by the high positive potential of the anode 6 but fail to reach the anode block 6 since they are caused to return to the cathode 50 by the negative charge on the screen 51. Hence the cold cathode 50 is bombarded by primary electrons. The magnetron operation may be controlled by regulating the potential of source 59.

In Figure 11 the small quantity of gas that remains in the tube after evacuation is ionized by the very high voltage from source 64 which is connected by wires 62 and 63 across the cathode 61 and the anode 60. The result of this ionization is a bombardment of the cathode 12 and the emission of secondary electrons. If the high voltage supply 64 is pulsed, the output current will also be pulsed.

In Figure 12 there is shown a thin tube 80 having the usual oxide coating adapted for secondary emission thereon. The total length of the cathode 80 may be 3 centimeters. One or both ends of the tube 80 may have coatings 82 which each extend for approximately one-tenth the total length of tube 80. Coatings 82 are suit-

able for thermionic emission and are provided with suitable heaters which may be either inside or outside tube 80 but are specifically illustrated in Figure 12 as heater coils 81 inside of tube 80. To start the magnetron, the heaters 81 are energized to cause emission of primary electrons from coatings 82. Some of these electrons strike the outside layer on tube 80 and cause secondary emission, which will from that point build up by itself.

It should be clearly understood that as for any features not specifically referred to herein that the devices shown in this specification are similar to the teachings of my said prior copending application. For example, said prior application teaches that the diameter of the cathode may be about 0.40 the inside diameter of the central cavity. This is true in the present invention.

We claim:

1. In a magnetron, an anode block defining a central cavity and a plurality of resonator cavities opening into the central cavity, a cold cathode comprising a thin cylindrical tube positioned axially in the central cavity, a coating on the outside of the tube for establishing secondary emission, means for passing cooling fluid through the inside of said tube to thereby cool the tube, and means for effecting bombardment of the outside of the tube with primary electrons to thereby start the magnetron into oscillation.
2. In a magnetron, an anode block defining a main cylindrical cavity and a plurality of resonator cavities opening into the main cavity, a substantially cylindrical secondary emission surface coaxial with as well as coextensive with the main cavity, a primary thermionic emitter for bombarding said surface to excite secondary emission therefrom comprising a filament wire positioned between said cathode and said anode, means for connecting a source of current to opposite ends of said wire and thereby to heat the wire to electron emission temperature, means for establishing a magnetic field in the main cavity and coaxial therewith, and means for establishing a high potential between said cathode and said anode block.
3. The magnetron defined in claim 2 in which said wire is positioned closer to the cathode than to the anode and is at all points equally spaced from the cathode.
4. The magnetron defined in claim 3 in which the wire is electrically connected to the cathode.
5. The magnetron defined in claim 2 in which the wire is electrically connected to the cathode.
6. The magnetron defined in claim 2 in which the cathode defines an elongated indent in the surface thereof, said indent being substantially parallel to the axis of the cathode, and means supporting said wire parallel to and closely adjacent the indented surface of the cathode and closer to the cathode surface than to the anode surface.
7. In a magnetron, an anode block defining a cylindrical cavity therein and a plurality of resonator cavities opening into the main cavity, an evacuated envelope surrounding the anode block, a hollow cylindrical cathode coaxial with the main cavity, two water pipes connected to the opposite ends of said cathode and extending respectively perpendicularly therefrom through the envelope, means on the surface of said cathode for establishing secondary emission upon bombardment by primary electrons, a thermionic emitter for bombarding said surface with primary electrons, means for establishing a magnetic field

parallel to said axis, and means for applying a potential between the anode and the cathode of such polarity as to render the anode positive.

8. In a magnetron, an anode block defining a main cylindrical cavity and a plurality of at least three resonator cavities separately opening into the main cavity, a secondary emission type of cathode located in the main cavity and along the axis thereof, the openings from the resonator cavities into the main cavity all intersecting a single plane that is perpendicular to the axis of and passes through said cathode, means for establishing the main magnetic field for the magnetron comprising means for setting up a strong magnetic field parallel to the axis of said main cavity, a source of potential for charging the anode positively with respect to the cathode, means adjacent the cathode for starting secondary emission by bombardment of the cathode by electrons, said magnetic field and said potential being of such magnitudes as to cause the electrons in the space between the cathode and anode to move in curved paths and such that some of the electrons in that space will move toward the cathode and bombard the latter.

9. In a magnetron, an anode block defining a main cylindrical cavity and a plurality of at least three resonator cavities symmetrically located around the main cavity and opening into it, a cylindrical cathode coated with a surface adapted for secondary emission, said cathode extending coaxial of the main cavity and substantially the entire distance between opposite faces of said block, a thermionic emitter comprising a member heated to electron emission temperature, said emitter being located adjacent said cathode whereby to bombard the latter, means for establishing a magnetic field parallel to the axis of said main cavity to operate the magnetron thereby causing electrons in the cathode-anode space to establish oscillations in the resonator cavities, and a source of potential connected between the cathode and the anode and arranged to charge the anode positively with respect to the cathode, said potential and said field being of such magnitudes as to cause some of the electrons emitted by said emitter and said cathode to move in a curved path about the outside surface of the cathode and to strike the cathode and thereby excite secondary emission from the cathode.

10. The device of claim 9 in which said cathode is hollow, a pair of pipes respectively connected to opposite ends of said cathode, and means for forcing a cooling fluid into one of the pipes, whereby to cool the cathode.

11. In a magnetron, an evacuated envelope having an anode block therein, said anode block defining a main cavity and a plurality of at least three resonator cavities therein, a secondary emission type of cathode located substantially in the center of the main cavity, a pilot cathode located nearby the first-named cathode, means for creating a main magnetic field transverse to the cathode-anode path, a source of potential and said field having such magnitudes as to cause some of the electrons in the cathode-anode space to take curved paths and then strike the first-named cathode thus bombarding it and heating it, said first-named cathode being of very large area as compared to that of the pilot cathode such that the first-named cathode can supply substantially all of the electrons involved in operation of the magnetron and whereby the pilot cathode will not be overheated in operation,



## 11

and a current path for heating the pilot cathode, said current path providing substantially the entire heating effect on the pilot cathode, and electron bombardment constituting substantially the entire heating of the first-named cathode.

12. The magnetron defined by claim 11 including in addition cooling means for cooling the first-named cathode without substantially cooling the pilot cathode.

13. The magnetron defined by claim 12 in which the pilot cathode comprises an oxide coated filament designed to operate normally at approximately 1500 degrees centigrade.

14. In a magnetron, an anode structure defining a cylindrical central cavity and a plurality of resonator cavities opening into the central cavity, a tubular cathode positioned axially in said central cavity and having an outer surface which emits electrons when bombarded by electrons, means adjacent the cathode for carrying away heat from the inside of the tubular cathode comprising means for passing a cooling fluid through the inside of the cathode, and means for establishing primary electrons in the space between the anode and the cathode to thereby start the magnetron.

15. The magnetron as defined in claim 14 in which the last-named means comprises a thermionic emitter located in the space between

## 12

the anode and the cathode, and the inner wall of the tubular cathode constituting the only wall which confines the cooling fluid inside of the cathode.

JOHN TURTON RANDALL.  
HENRY ALBERT HOWARD BOOT.

References Cited in the file of this patent

## UNITED STATES PATENTS

Number	Name	Date
2,063,342	Samuel	Dec. 8, 1936
2,163,157	Samuel	June 20, 1939
2,201,666	Hollman	May 21, 1940
2,217,745	Hansell	Oct. 15, 1940
2,244,318	Skellett	June 3, 1941
2,295,396	George	Sept. 8, 1942
2,409,038	Hansell	Oct. 8, 1946
2,411,601	Spencer	Nov. 26, 1946

## FOREIGN PATENTS

Number	Country	Date
509,102	Great Britain	July 11, 1939
582,489	Great Britain	Nov. 19, 1946
588,185	Great Britain	May 16, 1947
588,186	Great Britain	May 16, 1947
843,087	France	June 26, 1939
820,665	France	Nov. 16, 1937